

ROCKSHOX

Charger Damper Upgrade Kit



UPGRADE MANUAL



SAFETY FIRST!

We care about YOU. Please, always wear your safety glasses and protective gloves when servicing RockShox products. Protect yourself! Wear your safety gear!

⚠️ WARNING - PRESSURIZED DEVICE

Suspension products may contain pressurized air, nitrogen, springs, and oil. Always wear certified safety glasses (ANSI Z87.1, EN166 EU) when performing any service on a suspension product (suspension fork, rear shock, seatpost). Failure to wear proper safety glasses can result in **SERIOUS INJURY OR DEATH**.

RockShox Service

We recommend that you have your RockShox suspension serviced by a qualified bicycle mechanic. Servicing RockShox suspension requires knowledge of suspension components, as well as the use of specialized tools and lubricants/fluids. Failure to follow the procedures outlined in this service manual may cause damage to your component and void the warranty.

Visit www.sram.com/service for the latest *RockShox Spare Parts Catalog* and technical information. For order information, please contact your local SRAM distributor or dealer.

Information contained in this publication is subject to change at any time without prior notice.

Your product's appearance may differ from the pictures contained in this publication.

 For recycling and environmental compliance information, please visit: www.sram.com/en/company/about/environmental-policy-and-recycling.

Suspension Safety Precautions and Warnings

SAFETY INSTRUCTIONS

To avoid serious injury or death, you MUST understand and follow the safety information in this document.

WARNING - PRESSURIZED DEVICE

Suspension products may contain pressurized air, nitrogen, springs, and oil.

Always wear certified safety glasses (ANSI Z87.1, EN166 EU) when performing any service on a suspension product (suspension fork, rear shock, seatpost).

DO NOT attempt to disassemble a suspension product before the product is fully depressurized. Follow depressurization procedures and remove the air valve as instructed, before attempting disassembly of a suspension product.

When performing service on a suspension product, keep your eyes, face, and body away from any part or lubricant that can suddenly eject under high pressure. DO NOT direct any pressurized suspension part at a person.

DO NOT attempt to puncture, crush, or incinerate any assembled suspension product.

Failure to follow these preventative measures can result in SERIOUS INJURY OR DEATH.

WARNING - CRASH HAZARD

Parts must be tightened to the specified torque.

To avoid separation of parts, threadlocker must be applied as instructed. Failure to apply threadlocker could result in separation of the parts.

Retaining rings must be fully seated in the retaining ring groove. Confirm the retaining ring is fully seated in the retaining ring groove after installation.

Do not use vinegar of any type to clean any part of a RockShox suspension product. Vinegar can cause permanent damage to parts which can, over time, result in product structural failure.

Failure to follow these preventative measures can result in SERIOUS INJURY OR DEATH.

WARNING

Do not ingest oil, fluid, grease, lubricant, or cleaner. Ingestion could lead to SERIOUS INJURY OR DEATH. Seek immediate medical attention if any oil, fluid, grease, lubricant, or cleaner is ingested.

CAUTION

Suspension products may contain lubricants which can lead to skin irritation. Always wear nitrile gloves when servicing suspension products. Failure to properly protect your skin can result in irritation. Seek medical attention if your skin is adversely affected by any suspension oil, fluid, grease, lubricant, and/or cleaner.

Always wear safety glasses. Do not allow oil, fluid, grease, lubricant, or cleaner to contact your eyes or face. Seek immediate medical attention if irritation occurs.

Use care when working with sharp tools and parts. Never use sharp tools coated with oil and/or grease. Clean and remove all oil and/or grease from your hands and gloves, and tools before working with any sharp tool or part. Failure to do so can result in personal injury.

Place an oil pan on the floor underneath the product during service to catch any drained or spilled fluids. To avoid a slip and fall, and possible injury or harm, immediately clean any oil, fluid, grease, or lubricant from the floor in your work area.

TABLE OF CONTENTS

ROCKSHOX SERVICE	3
SUSPENSION SAFETY PRECAUTIONS AND WARNINGS	3
PART PREPARATION AND SERVICE PROCEDURES	5
PART PREPARATION	5
SERVICE PROCEDURES.....	5
PARTS, TOOLS, AND SUPPLIES.....	6
MODEL CODE IDENTIFICATION	7
WARRANTY AND TRADEMARK.....	7
COMPATIBILITY	7
DAMPER REMOVAL	13
MOTION CONTROL DAMPER REMOVAL (SID / REBA / BLUTO / PIKE / REVELATION / LYRIK / YARI / DOMAIN).....	15
CHARGER DAMPER REMOVAL (SID / PIKE / REVELATION / LYRIK / YARI / ZEB)	19
CHARGER 2 AND 2.1 DAMPER REMOVAL (SID / PIKE / REVELATION / LYRIK / YARI / ZEB)	22
CHARGER R DAMPER REMOVAL (ZEB).....	26
CHARGER DAMPER RC AND CHARGER 2 RC2 REMOVAL (BOXXER)	27
RUSH DAMPER REMOVAL (SID BASE)	30
CHARGER RACE DAY DAMPER REMOVAL (SID).....	32
CHARGER RACE DAY 2 DAMPER REMOVAL (SID).....	35
REBOUND DAMPER CARTRIDGE REMOVAL (RUDY XPLR BASE)	37
DAMPER UPGRADE INSTALLATION	41
CHARGER 2 RLC DAMPER INSTALLATION (SID / REBA / BLUTO)	41
CHARGER 2 RCT REMOTE DAMPER INSTALLATION (PIKE / REVELATION / LYRIK / YARI)	43
CHARGER 2.1 DAMPER INSTALLATION (PIKE / REVELATION / LYRIK / YARI / ZEB / DOMAIN)	46
CHARGER 2.1 DAMPER RC2 INSTALLATION (BOXXER).....	48
CHARGER RACE DAY 2 DAMPER INSTALLATION (SID / REBA / BLUTO).....	50
CHARGER RACE DAY DAMPER INSTALLATION (RUDY XPLR).....	52
LOWER LEG ASSEMBLY	53
LOWER LEG INSTALLATION	53
LOWER LEG INSTALLATION (RUDY XPLR).....	57

Part Preparation

Remove the component from the bicycle before service.

Disconnect and remove the remote cable or hydraulic hose from the fork or rear shock, if applicable. For additional information about RockShox remotes, user manuals are available at www.sram.com.

Clean the exterior of the product with mild soap and water to avoid contamination of internal sealing part surfaces.

Service Procedures

The following procedures should be performed throughout service, unless otherwise specified.

Clean the part with RockShox Suspension Cleaner or isopropyl alcohol and a clean, lint-free shop towel. For hard to reach places (e.g. upper tube, lower leg), wrap a clean, lint-free shop towel around a non-metallic dowel to clean the inside.

Clean the sealing surface on the part and inspect it for scratches.

⚠ WARNING - CRASH HAZARD

DO NOT use vinegar of any type to clean any part of a RockShox suspension product. Vinegar can cause permanent damage to parts which can, over time, result in product structural failure, serious injury, and possibly death.



Replace the o-ring or seal with a new one from the service kit. Use your fingers or a pick to pierce and remove the old seal or o-ring.

Apply grease to the new seal or o-ring.

NOTICE

Do not scratch any sealing surfaces when servicing the product. Scratches can cause leaks. Consult the spare parts catalog to replace the damaged part.

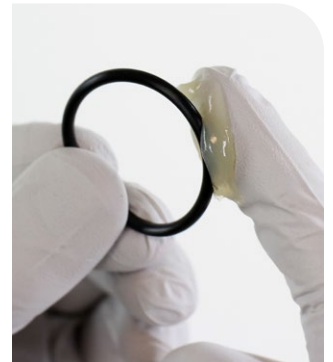

Use aluminum soft jaws when placing a part in a bench vise.

Tighten the part with a torque wrench to the torque value listed in the red bar. When using a crowfoot socket and torque wrench, install the crowfoot socket at 90 degrees to the torque wrench.

⚠ WARNING - CRASH HAZARD

Parts must be tightened to the specified torque. Failure to do so can result in SERIOUS INJURY OR DEATH.

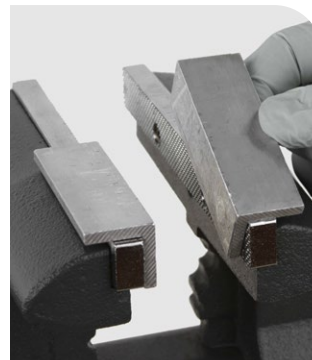

Parts

- Damper Upgrade Kit (see [Compatibility](#))

Safety and Protection Supplies

- Apron
- Clean, lint-free shop towels
- Nitrile gloves
- Oil pan
- Safety glasses

Lubricants and Fluids

- Isopropyl alcohol or RockShox Suspension Cleaner
- Maxima PLUSH Dynamic Suspension Lube Light or RockShox 0w-30 Suspension Oil
- Maxima PLUSH Dynamic Suspension Lube Heavy or RockShox 0w-30 Suspension Oil
- RockShox 15wt Suspension Oil
- RockShox Dynamic Seal Grease
- SRAM Butter Grease

RockShox Tools

- RockShox Schrader Valve Tool
- RockShox shock pump

Bicycle Tools

- Bicycle work stand
- Shock pump

Common Tools

- RockShox Top Cap/Cassette Tool (3/8"/24 mm)
- Hex bit sockets: 2 mm, 2.5 mm, 5 mm, 8 mm, 11 mm
- Hex wrenches: 1.5 mm, 2 mm, 2.5 mm, 4 mm, 5 mm, 6 mm, 8 mm, 11 mm
- Internal retaining ring pliers
- Long plastic or wooden dowel
- Open end wrench: 10 mm, 24 mm (XLoc)
- Pick
- Rubber or plastic mallet
- Sockets: 6 mm, 24 mm, 30 mm
- Torque wrench
- TORX T10 wrench

Model Code Identification

Product model code and specification details can be identified with the serial number on the product. Model codes can be used to identify the product type, series name, model name, and product version associated with the production model year. Product details can be used to identify spare parts, service kit, and lubricant compatibility.

Model Code example: **FS-PIKE-SEL-B3**

FS = Product Type - **Front Shock**

PIKE = Platform/Series - **Pike**

SEL = Model - **Select**

B3 = Version - (**B** - second generation, **3** - third iteration)

To identify the model code, locate the serial number on the product and enter it into the **Search by Model Name or Serial Number** field at www.sram.com/service.

Warranty and Trademark

For SRAM Warranty information, visit: www.sram.com/warranty.

For SRAM Trademark information, visit: www.sram.com/website-terms-of-use.

Compatibility

NOTICE

Damper top caps and upper tube thread pitches may vary; consult the table to verify compatibility before damper upgrade installation. Installation of an incompatible damper top cap will damage the upper tube and damper top cap threads. If you are unsure what model year or generation you have, contact your local SRAM distributor or dealer.

Use **ONLY** RockShox, SRAM, and Maxima suspension oils/fluids and grease, unless otherwise specified. Use of any other lubricants can damage seals and decrease performance.

Suspension oil/fluid - Maxima PLUSH Dynamic Suspension Lube and RockShox 0w-30 suspension oils/fluids are forward and backward compatible with RockShox Dynamic Seal Grease and SRAM Butter Grease.

Refer to the appropriate RockShox suspension fork service manual, available at www.sram.com/service, for service specifications and procedures.

30 mm Chassis- Max Travel 40 mm						Lower Leg Oil			
Fork	Model	Model Code	Year	Max Travel (mm)	Upgrade Kit	Damper Side		Spring Side	
						Oil (wt)	Volume (mL)	Oil (wt)	Volume (mL)
RUDY	BASE	FS-RUDY-BSE-A1	2022+	40	00.4020.546.004 AM Upgrade Kit Charger Race Day Rudy Crown	PLUSH Heavy*	10	PLUSH Heavy*	10

* Maxima PLUSH Dynamic Suspension Lube

32 mm Chassis- Max Travel 120 mm						Lower Leg Oil			
Fork	Model	Model Code	Year	Max Travel (mm)	Upgrade Kit	Damper Side		Spring Side	
						Oil (wt)	Volume (mL)	Oil (wt)	Volume (mL)
SID	RL	FS-SID-RL-A2	2013	120	00.4018.783.003 AM Upgrade Kit Charger RLC SID/Reba Crown 120 00.4018.783.011 AM Upgrade Kit Charger RLC SID/Reba Remote 120	PLUSH Heavy*	5	15**	5
		FS-SID-RL-A3	2014-2015						
		FS-SID-RL-A4	2016						
		FS-SID-RL-B3	2019						
	RLT	FS-SID-RLT-A2	2013						
		FS-SID-RLT-A3	2014-2015						
		FS-SID-RLT-A4	2016						
	RLC	FS-SID-RLC-B1	2019						
	RCT3	FS-SID-RCT3-A2	2013						
		FS-SID-RCT3-A3	2014-2015						
		FS-SID-RCT3-A4	2016						
	XX	FS-SID-XX-A2	2013						
		FS-SID-XX-A3	2014-2015						
		FS-SID-XX-A4	2016						
	WORLD CUP	FS-SID-WC-A2	2013						
FS-SID-WC-A3		2014-2015							
FS-SID-WC-A4		2016							
XX WORLD CUP	FS-SID-XXWC-A2	2013							
	FS-SID-XXWC-A3	2014-2015							
	FS-SID-XXWC-A4	2016							
SELECT	FS-SID-SEL-B4	2020							
SELECT+	FS-SID-SELP-B4								
ULTIMATE	FS-SID-ULT-B4								
REBA	RL	*FS-REBA-RL-A2	2013	120	00.4018.783.003 AM Upgrade Kit Charger RLC SID/Reba Crown 120 00.4018.783.011 AM Upgrade Kit Charger RLC SID/Reba Remote 120	PLUSH Heavy*	5	15**	5
		*FS-REBA-RL-A3	2014						
		*FS-REBA-RL-A4	2015						
		*FS-REBA-RL-A5	2016						
		*FS-REBA-RL-A6	2017						
		**FS-REBA-RL-A7	2018						
		*FS-REBA-RL-A8	2019-2020						
		*FS-REBA-RL-A9	2021						
	RLT	*FS-REBA-RLT-A2	2013						
		*FS-REBA-RLT-A3	2014						
		*FS-REBA-RLT-A4	2015						
		*FS-REBA-RLT-A5	2016-2017						
		BLUTO	RL					FS-BLTO-RLT-A1	
FS-BLTO-RLT-A2	2016								
FS-BLTO-RLT-A3	2017-2018								
FS-BLTO-RLT-A4	2019-2021								
RCT3	FS-BLTO-RCT3-A2		2016						
	FS-BLTO-RCT3-A3	2017-2018							

DO NOT install a damper upgrade kit with a maximum travel that is less than the fork's maximum travel.

* Maxima PLUSH Dynamic Suspension Lube

** RockShox 15wt Suspension Oil ONLY. Not compatible with 0w-30 and Maxima PLUSH Dynamic Suspension Lube.

† Charger Upgrade kits are NOT compatible with SID 26" and Reba 26" wheel fork models.

‡ Some Reba fork variants, including those on some Specialized and Trek bicycles, are not compatible with Charger Upgrade kits. Contact [SRAM Rider Support](#) for more information.

32 mm Chassis- Max Travel 100 mm						Lower Leg Oil			
Fork	Model	Model Code	Year	Max Travel (mm)	Upgrade Kit	Damper Side		Spring Side	
						Oil (wt)	Volume (mL)	Oil (wt)	Volume (mL)
SID SID SL	RL	FS-SID-RL-B1	2017	100, 110	00.4018.783.009 AM Upgrade Kit Charger RLC SID/Reba Crown 100 00.4018.783.010 AM Upgrade Kit Charger RLC SID/Reba Remote 100 00.4318.087.000 AM Upgrade Kit - Charger Race Day 2 3 Position SID SL 32mm D1 Crown 110 00.4318.087.001 AM Upgrade Kit - Charger Race Day 2 3 Position SID SL 32mm D1 Remote 110 00.4318.086.000 AM Upgrade Kit - Charger Race Day 2 2 Position SID SL 32mm D1 Crown 110 00.4318.086.001 AM Upgrade Kit - Charger Race Day 2 2 Position SID SL 32mm D1 Remote 110	PLUSH Heavy*	5	15**	5
		FS-SID-RL-B2	2018						
		FS-SID-RL-B3	2019						
	RLC	FS-SID-RLC-A1	2017						
		FS-SID-RLC-A2	2018						
		FS-SID-RLC-B1	2019						
	XX	FS-SID-XX-B1	2017						
		FS-SID-XX-B2	2018						
		FS-SID-XX-B3	2019						
	WORLD CUP	FS-SID-WC-B1	2017						
		FS-SID-WC-B2	2018						
		FS-SID-WC-B3	2019						
	BASE	FS-SIDS-BSE-C1	2022-2023						
		FS-SIDS-BSE2-D1	2024+						
		FS-SIDS-BSE3-D1	2024+						
	SELECT	FS-SID-SEL-B4	2020						
		FS-SIDS-SEL-C1	2021-2023						
		FS-SIDS-SEL2-D1	2024+						
		FS-SIDS-SEL3-D1	2024+						
	SELECT+	FS-SID-SELP-B4	2020						
		FS-SIDS-SELP-C1	2021-2023						
		FS-SIDS-SLP2-D1	2024+						
		FS-SIDS-SLP3-D1	2024+						
	ULTIMATE	FS-SID-ULT-B4	2020						
FS-SIDS-ULT-C1		2021-2023							
FS-SIDS-ULT2-D1		2024+							
FS-SIDS-ULT3-D1		2024+							
REBA	RL	†FS-REBA-RL-A7	2018						
		†FS-REBA-RL-A8	2019-2020						
		†FS-REBA-RL-A9	2021+						
BLUTO	RL	FS-BLTO-RLT-A1	2015						
		FS-BLTO-RLT-A2	2016						
		FS-BLTO-RLT-A3	2017-2018						
		FS-BLTO-RLT-A4	2019-2021						
	RCT3	FS-BLTO-RCT3-A2	2016						
		FS-BLTO-RCT3-A3	2017-2018						

DO NOT install a damper upgrade kit with a maximum travel that is less than the fork's maximum travel.

* Maxima PLUSH Dynamic Suspension Lube

** RockShox 15wt Suspension Oil ONLY. Not compatible with 0w-30 and Maxima PLUSH Dynamic Suspension Lube.

† Charger Upgrade kits are NOT compatible with SID 26" and Reba 26" wheel fork models.

‡ Some Reba fork variants, including those on some Specialized and Trek bicycles, are not compatible with Charger Upgrade kits. Contact [SRAM Rider Support](#) for more information.

35 mm Chassis						Lower Leg Oil									
Fork	Model	Model Code	Year	Max Travel (mm)	Upgrade Kit	Damper Side		Spring Side							
						Oil (wt)	Volume (mL)	Oil (wt)	Volume (mL)						
SID	BASE	FS-SID-BSE-C1	2022-2023	120	00.4318.087.002 AM Upgrade Kit - Charger Race Day 2 3 Position SID 35 D1 Crown 120	PLUSH Heavy*	10	PLUSH Heavy*	10						
		FS-SID-BSE2-D1	2024+						15						
		FS-SID-BSE3-D1	2024+						15						
	SELECT	FS-SID-SEL-C1	2021-2023						00.4318.087.003 AM Upgrade Kit - Charger Race Day 2 3 Position SID 35 D1 Remote 120	10					
		FS-SID-SEL2-D1	2024+							15					
		FS-SID-SEL3-D1	2024+							15					
	SELECT+	FS-SID-SELP-C1	2021-2023						00.4318.086.002 AM Upgrade Kit - Charger Race Day 2 2 Position SID 35 D1 Crown 120	10					
		FS-SID-SLP2-D1	2024+							15					
		FS-SID-SLP3-D1	2024+							15					
	ULTIMATE	FS-SID-ULT-C1	2021-2023						00.4318.086.003 AM Upgrade Kit - Charger Race Day 2 2 Position SID 35 D1 Remote 120	10					
		FS-SID-ULT2-D1	2024+							15					
		FS-SID-ULT3-D1	2024+							15					
PIKE	RC	FS-PIKE-RC-A1	2014-2015	160	00.4020.169.000 AM Upgrade Kit Charger 2.1 RCT3 Pike 26 Crown 00.4020.169.001 AM Upgrade Kit Charger 2.1 RCT3 Pike 27.5 Crown 00.4020.169.002 AM Upgrade Kit Charger 2.1 RCT3 Pike 29 Crown 00.4020.169.003 AM Upgrade Kit Charger 2.1 RCT3 Pike B27.5(A2), B27.5/B29(B1-B4) Crown 00.4020.169.004 AM Upgrade Kit Charger 2.1 RCT3 Pike B29(A1-A2) Crown	PLUSH Light*	10	PLUSH Light*	10						
		FS-PIKE-RC-A2	2016-2017												
	RCT3	FS-PIKE-RCT3-A1	2014-2015												
		FS-PIKE-RCT3-A2	2016-2017												
	RC	FS-PIKE-RC-A2	2016-2017												
		FS-PIKE-RC-B1	2018												
	RCT3	FS-PIKE-RCT3-A2	2016-2017												
		FS-PIKE-RCT3-B1	2018												
	RC	FS-PIKE-RC-B1	2018												
		FS-PIKE-RC-B2	2019												
	RCT3	FS-PIKE-RCT3-B1	2018												
		FS-PIKE-RCT3-B2	2019												
	SELECT	FS-PIKE-SEL-B3	2020												
		FS-PIKE-SEL-B4	2021-2022												
	SELECT+	FS-PIKE-SELP-B3	2020												
		FS-PIKE-SELP-B4	2021-2022												
	BASE	FS-PIKE-BSE-C1	2023+							140	00.4318.063.000 AM Upgrade Kit Charger 3 RC2 ButterCups Pike C1 B27.5 B29 Crown 140		30		15
	SELECT	FS-PIKE-SEL-C1	2023+												
	SELECT+	FS-PIKE-SELP-C1	2023+												
	ULTIMATE+	FS-PIKE-ULT-C1	2023+												

DO NOT install a damper upgrade kit with a maximum travel that is less than the fork's maximum travel.

* Maxima PLUSH Dynamic Suspension Lube

Pike C1: Refer to the 2023+ ZEB Lyrik Pike Service Manual for damper removal and installation procedures.

35 mm Chassis						Lower Leg Oil									
Fork	Model	Model Code	Year	Max Travel (mm)	Upgrade Kit	Damper Side		Spring Side							
						Oil (wt)	Volume (mL)	Oil (wt)	Volume (mL)						
REVELATION	RC	FS-RVL-RC-A1	2018	160	00.4020.169.003 AM Upgrade Kit Charger 2.1 RCT3 Pike B27.5(A2), B27.5/B29(B1-B4) Crown 00.4020.169.005 AM Upgrade Kit Charger 2.1 RC2 Pike B27.5(A2), B27.5/B29(B1-B4) Crown	PLUSH Light*	10	PLUSH Light*	10						
		FS-RVL-RC-A2	2019-2020												
		FS-RVL-RC-A3	2021+												
	CHARGER RC	FS-RVL-CHRC-A1	2019												
LYRIK	RC	FS-LYRK-RC-B1	2016-2017	180	00.4020.170.001 AM Upgrade Kit Charger 2.1 RCT3 LYRIK Crown 00.4020.170.000 AM Upgrade Kit Charger 2.1 RC2 LYRIK Crown	PLUSH Light*	10	PLUSH Light*	10						
		FS-LYRK-RC-C1	2018												
		FS-LYRK-RC-C2	2019												
	RCT3	FS-LYRK-RCT3-A1	2016-2017												
		FS-LYRK-RCT3-B1	2018												
		FS-LYRK-RCT3-C1	2019												
	RC2	FS-LYRK-RC2-C1	2019												
	SELECT	FS-LYRK-SEL-C2	2020												
		FS-LYRK-SEL-C3	2021-2022												
	SELECT+	FS-LYRK-SELP-C2	2020												
		FS-LYRK-SELP-C3	2021+												
	BASE	FS-LYRK-BSE-D1	2023+							160	00.4318.063.001 AM Upgrade Kit Charger 3 RC2 ButterCups Lyrik D1 B27.5 B29 Crown 160	PLUSH Light*	30	PLUSH Light*	15
	SELECT	FS-LYRK-SEP-D1	2023+												
SELECT+	FS-LYRK-SELP-D1	2023+													
ULTIMATE	FS-LYRK-ULT-D1	2023+													

DO NOT install a damper upgrade kit with a maximum travel that is less than the fork's maximum travel.

* Maxima PLUSH Dynamic Suspension Lube

Lyrik D1: Refer to the 2023+ ZEB Lyrik Pike Service Manual for damper removal and installation procedures.

38 mm Chassis						Lower Leg Oil			
Fork	Model	Model Code	Year	Max Travel (mm)	Upgrade Kit	Damper Side		Spring Side	
						Oil (wt)	Volume (mL)	Oil (wt)	Volume (mL)
YARI	RC	FS-YARI-RC-A1	2016-2017	180	00.4020.170.001 AM Upgrade Kit Charger 2.1 RCT3 LYRIK Crown 00.4020.170.000 AM Upgrade Kit Charger 2.1 RC2 LYRIK Crown	PLUSH Light*	10	PLUSH Light*	10
		FS-YARI-RC-B1	2018						
		FS-YARI-RC-B2	2019-2020						
		FS-YARI-RC-B3	2021+						
	CHARGER RC	FS-YARI-CHRC-B1	2019						
BOXXER	RC	FS-BXR-RC-C1	2019	200	00.4020.171.000 AM Upgrade Kit Charger 2.1 RC2 BoXXer 27.5 29 00.4318.063.009 AM Upgrade Kit Charger 3 RC2 ButterCups BoXXer D1 B27.5 B29 200	PLUSH Light*	10	PLUSH Light*	10
	WORLD CUP	FS-BXR-WC-C1	2019						
	SELECT	FS-BXR-SEL-C2	2020-2023						
	BASE	FS-BXR-BSE-D1	2024+						
	ULTIMATE	FS-BXR-ULT-D1	2024+						
DOMAIN	R	FS-DOMN-R-B1	2022+	180	00.4318.048.000 AM Upgrade Kit Charger 2.1 RC2 ZEB A1 Crown	PLUSH Light*	10	PLUSH Light*	10
	RC	FS-DOMN-RC-B1	2022+						
ZEB	R	FS-ZEB-RC-A1	2021-2022	190	00.4318.048.000 AM Upgrade Kit Charger 2.1 RC2 ZEB A1 B27.5 B29 Crown 00.4318.063.002 AM Upgrade Kit Charger 3 RC2 ButterCups ZEB A2 B27.5 B29 Crown 190	PLUSH Light*	20	PLUSH Light*	20
	SELECT	FS-ZEB-SEL-A1	2021-2022						
	SELECT+	FS-ZEB-SELP-A1	2021-2022						
	BASE	FS-ZEB-BSE-A2	2023+						
	SELECT	FS-ZEB-SEP-A2	2023+						
	SELECT+	FS-ZEB-SELP-A2	2023+						
	ULTIMATE	FS-ZEB-ULT-A2	2023+						

DO NOT install a damper upgrade kit with a maximum travel that is less than the fork's maximum travel.

* Maxima PLUSH Dynamic Suspension Lube

BoXXer D1: Refer to the 2024+ BoXXer Service Manual for damper removal and installation procedures.

ZEB A2: Refer to the 2023+ ZEB Lyrik Pike Service Manual for damper removal and installation procedures.

Damper Removal

The procedure for removing the damper is similar across RockShox front suspension forks. Your fork's knobs, bolts, and chassis may appear different from the pictures. Consult your fork's service manual for more detailed instructions.

- 1 Remove the air valve cap.



- 2 Depress the Schrader valve and release all air pressure.
Remove the Schrader valve core from the top cap and set it aside.

CAUTION - EYE HAZARD

Verify all pressure is removed from the fork before proceeding. Failure to do so can result in injury and/or damage to the fork. Wear safety glasses.

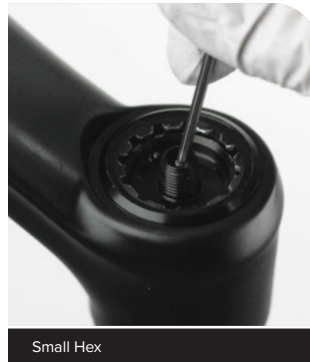

Small Hex

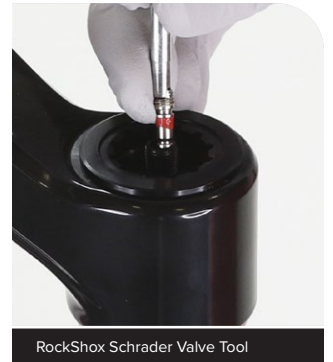

RockShox Schrader Valve Tool

- 3 Loosen the rebound adjuster knob screw, if present.

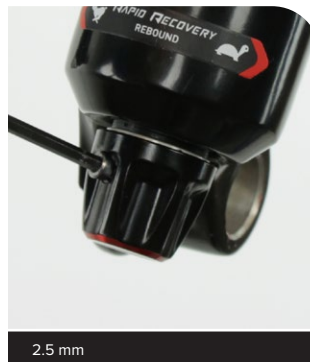

2.5 mm



Remove the rebound adjuster knob.



Charger Race Day (2) Damper (SID Ultimate)

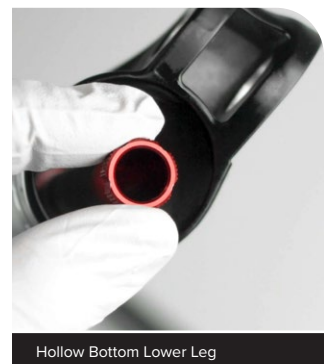

Hollow Bottom Lower Leg

4 Place an oil pan beneath the fork to catch the draining oil.

⚠ CAUTION

Place an oil pan on the floor underneath the product during service to catch any drained or spilled fluids. To avoid a slip and fall, and possible injury or harm, immediately clean any oil, fluid, grease, or lubricant from the floor in your work area.



SID / REBA / BLUTO Continue with [Motion Control](#), [Charger Damper](#), [Charger 2 or 2.1 Damper](#), [Rush Damper \(SID BASE\)](#), [Charger Race Day Damper](#), or [Charger Race Day 2 Damper](#) removal.

PIKE / REVELATION / LYRIK / YARI / DOMAIN Continue with [Motion Control](#), [Charger Damper](#), or [Charger 2 or 2.1 Damper](#) removal.

ZEB Continue with [Charger Damper](#), [Charger R Damper](#), or [Charger 2 or 2.1 Damper](#) Removal.

BOXXER Continue with [BoXXer Charger RC and Charger 2 RC2 Removal](#).

RUDY XPLR Continue with [Rebound Damper Cartridge Removal \(RUDY XPLR\)](#).

Motion Control Damper Removal (SID / REBA / BLUTO / PIKE / REVELATION / LYRIK / YARI / DOMAIN)

The procedure for removing the damper is similar across RockShox front suspension forks. Your fork's knobs, bolts, and damper may appear different from the pictures. Consult your fork's service manual for more detailed instructions.

⚠ CAUTION

Place an oil pan on the floor underneath the product during service to catch any drained or spilled fluids. To avoid a slip and fall, and possible injury or harm, immediately clean any oil, fluid, grease, or lubricant from the floor in your work area.

- 1 Loosen both bottom bolts 3 to 4 turns.

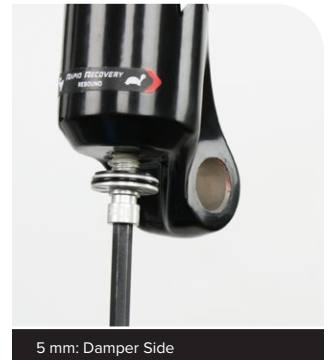
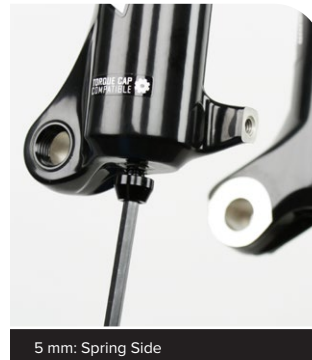

Strike each bottom bolt, or a hex wrench inserted into the bottom bolt for hollow bottom lower legs, to dislodge the shafts from the lower leg on each side. The bolt head should contact the bottom of the lower leg.

Remove each bottom bolt. Clean each bolt and set them aside.

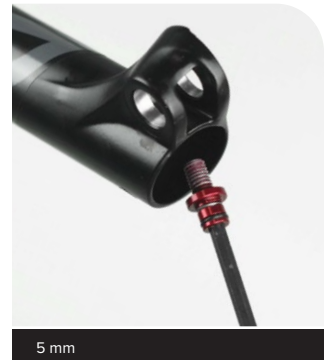
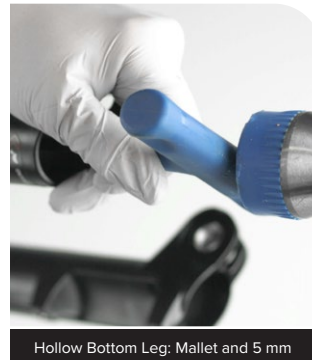
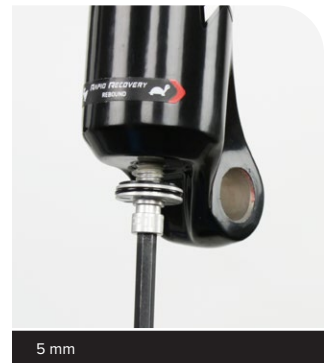
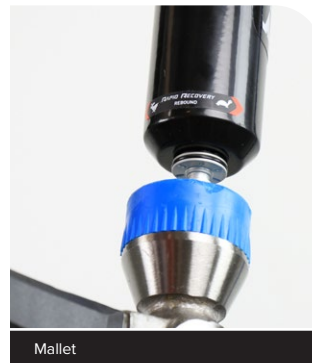

- 2 Firmly pull the lower leg downward until fluid begins to drain. Continue pulling downward to remove the lower leg.

If the lower leg does not slide off of the upper tube or if oil does not drain from either side, the press fit of the shaft(s) into the lower leg may still be engaged. Reinstall the bottom bolts 2 to 3 turns and repeat the previous step.

NOTICE

Do not strike the fork arch with any tool when removing the lower leg as this could damage the lower leg.

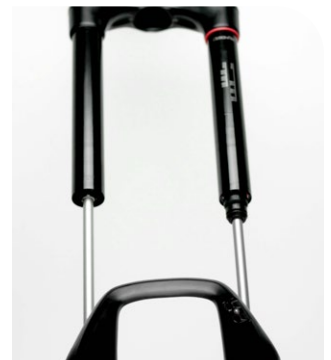

- 3** Clean the inside and outside of the lower leg. Clean the wiper seals.
Set the lower leg aside.



- 4 Crown:** Rotate the adjuster knob to the open position.



- 5 Crown:** Remove the retention screw, nut (some models), and compression adjuster knob(s).

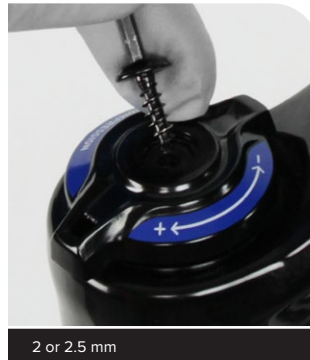

- 6 Remote:** Remove the retention screw and cable spool. Loosen the remote cable stop collar clamping bolt, and remove it. Remove the lower remote spool, if present.

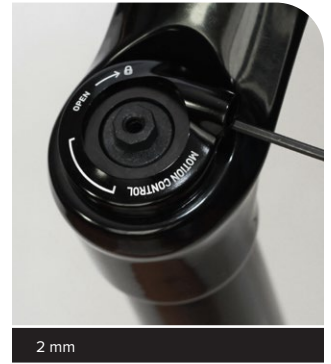
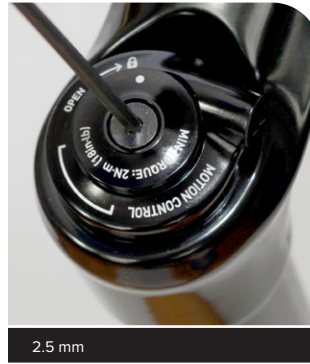

- 7** Unthread the compression damper top cap. Remove the compression damper by pulling up firmly and slowly, while gently rotating the damper in a circular motion.

NOTICE

Do not force the damper out of the upper tube if there is resistance. This can cause separation of the piston from the damper tube.

CAUTION

Always wear safety glasses. Do not allow oil, fluid, grease, lubricant, or cleaner to contact your eyes or face. Seek immediate medical attention if irritation occurs.

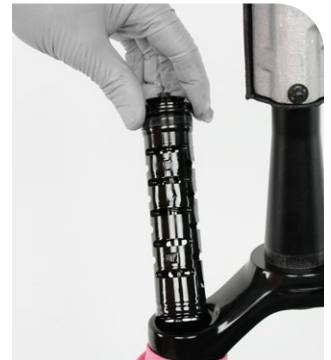
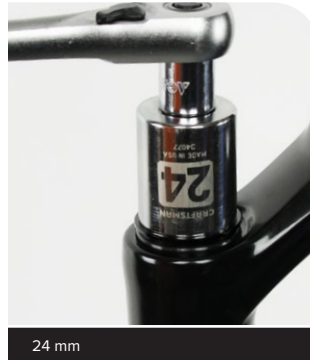

XLoc Remote: Press the XLoc remote button to the compressed (open) position. Unthread the compression damper.

Remove the compression damper by pulling up firmly and slowly, while gently rotating the damper in a circular motion.

NOTICE

Do not force the damper out of the upper tube if there is resistance. This can cause separation of the piston from the damper tube.



- 8 Remove the fork from the work stand and pour the suspension oil into an oil pan.



- 9 Clamp the fork into the work stand. Thread the bottom bolt onto the rebound damper shaft and push the shaft into the upper tube.



- 10 Remove the retaining ring.

CAUTION

Use care when working with sharp tools and parts. Never use sharp tools coated with oil and/or grease. Clean and remove all oil and/or grease from your hands and gloves, and tools before working with any sharp tool or part. Failure to do so can result in personal injury.

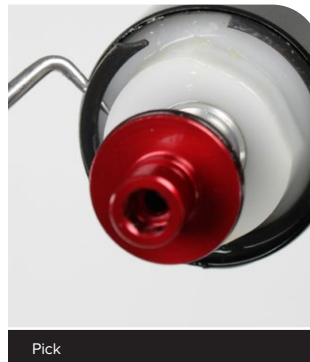

Pick

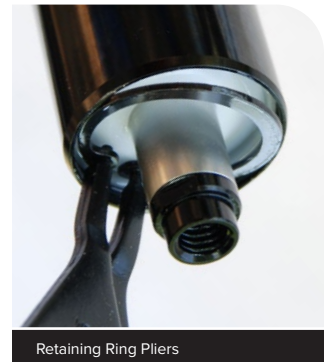

Retaining Ring Pliers

- 11 Pull the rebound shaft to full extension. Remove the rebound damper and seal head. Remove the bottom bolt, if installed.



SID / REBA / BLUTO Continue with [Charger 2 RLC Damper](#) or [Charger Race Day 2 Damper](#) installation.

PIKE / REVELATION / LYRIK / YARI / DOMAIN Continue with [Charger 2 RCT Remote Damper](#) or [Charger 2.1 Damper](#) Installation.

Charger Damper Removal (SID / PIKE / REVELATION / LYRIK / YARI / ZEB)

The procedure for removing the damper is similar across RockShox front suspension forks. Your fork's knobs, bolts, and damper may appear different from the pictures. Consult your fork's service manual for more detailed instructions.

Pike C1, Lyrik D1, ZEB A2: Refer to the 2023+ ZEB Lyrik Pike Service Manual for damper removal and installation procedures.

⚠ CAUTION

Place an oil pan on the floor underneath the product during service to catch any drained or spilled fluids. To avoid a slip and fall, and possible injury or harm, immediately clean any oil, fluid, grease, or lubricant from the floor in your work area.

- 1 Loosen the damper side bottom bolt 3 to 4 turns.

Strike the damper side bottom bolt to dislodge the shaft from the lower leg on the damper side. The bolt head should contact the bottom of the lower leg.

Remove the damper side bottom bolt. Clean it and set it aside.

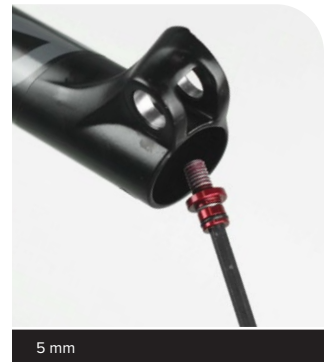
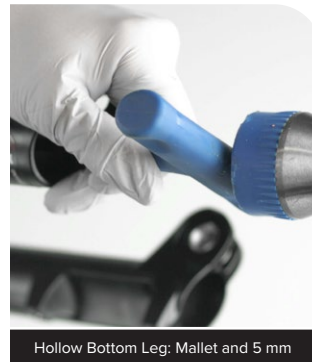
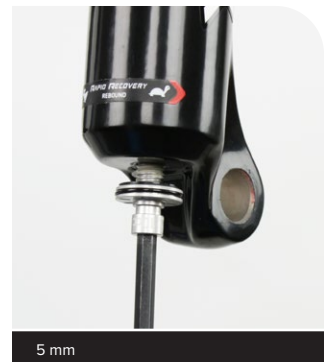
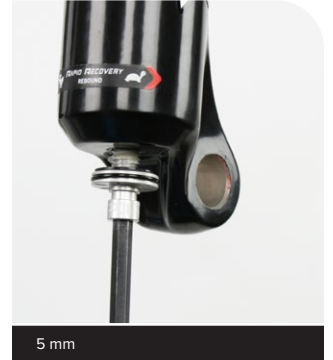
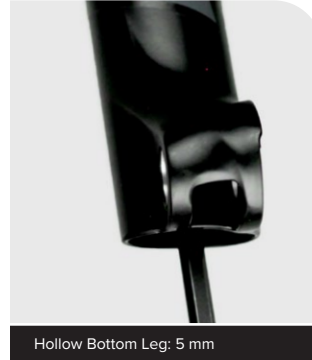

- 2 **Crown:** Turn the lockout adjuster knob to the open, unlocked position.



3 Crown: Remove the knob retaining screw and remove the compression adjuster knob.

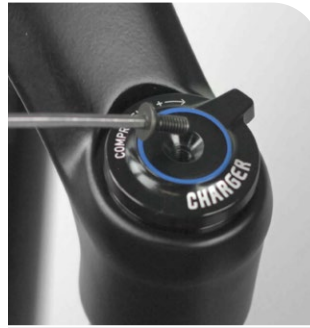

2 or 2.5 mm



RC: 4 mm

RCT3 Only: Remove the low speed adjuster knob screw. Remove the low speed adjuster knob.

Remove the knob retaining nut. Remove the compression adjuster knob.



RCT3: 2 mm



RCT3: 6 mm

4 Remote: Loosen the set screw and remove the cable spool and cable stop collar.



RL R: 2 or 2.5 mm



RL R: 2 or 2.5 mm

- 5** Unthread the damper top cap and remove the damper assembly.
Clean the upper tube threads.



Top Cap / Cassette Tool



24 or 30 mm

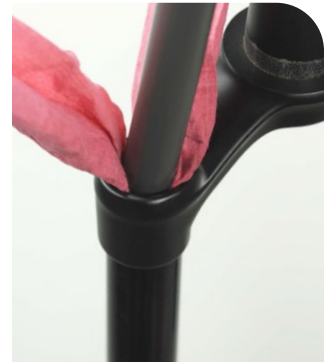

SID Continue with [Charger 2 RLC Damper](#) OR [Charger Race Day 2 Damper](#) installation.

PIKE / REVELATION / LYRIK / YARI / ZEB Continue with [Charger 2.1 Damper](#) installation.

PIKE / REVELATION / LYRIK / YARI Continue with [Charger 2 RCT Remote Damper](#) installation.

Charger 2 and 2.1 Damper Removal (SID / PIKE / REVELATION / LYRIK / YARI / ZEB)

The procedure for removing the damper is similar across RockShox front suspension forks. Your fork's knobs, bolts, and damper may appear different from the pictures. Consult your fork's service manual for more detailed instructions.

Pike C1, Lyrik D1, ZEB A2: Refer to the 2023+ ZEB Lyrik Pike Service Manual for damper removal and installation procedures.

⚠ CAUTION

Place an oil pan on the floor underneath the product during service to catch any drained or spilled fluids. To avoid a slip and fall, and possible injury or harm, immediately clean any oil, fluid, grease, or lubricant from the floor in your work area.

- 1 Loosen the damper side bottom bolt 3 to 4 turns.

Strike the damper side bottom bolt to dislodge the shaft from the lower leg on the damper side. The bolt head should contact the bottom of the lower leg.

Remove the damper side bottom bolt. Clean it and set it aside.

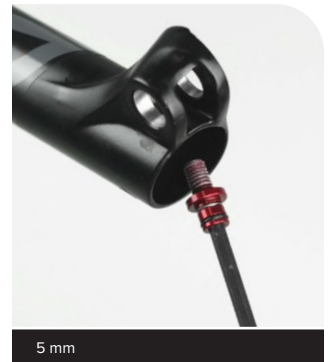
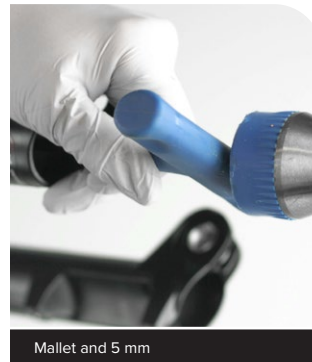
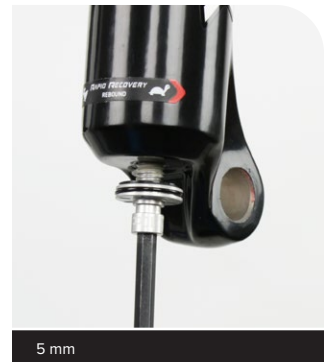
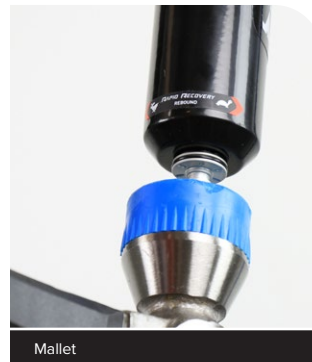
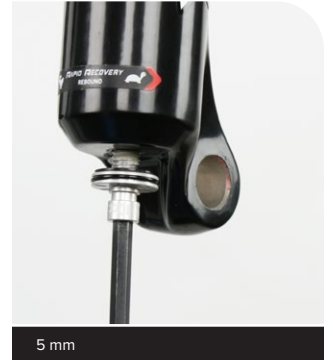
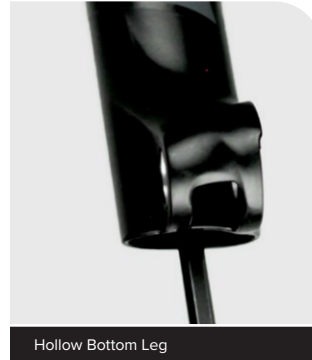

2 Crown adjust: Turn the lockout adjuster knob to the open, unlocked position.



RLC



RL / RC



RCT3



RC2

3 Crown adjust: Remove the knob retaining screw.



RLC: 2 mm



RL: 2 or 2.5 mm



RC2 / RCT3: 2 mm

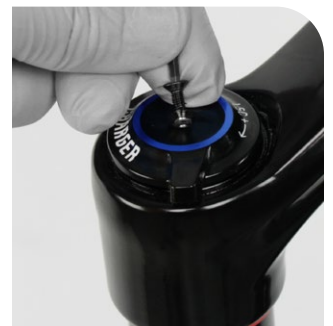

RC: 2 mm

Remove the low speed compression and lockout knob from the top cap.



RLC



RCT3

Remove the compression mode adjuster knob.



RC2 / RCT3



RC / RL

4 Remote: Remove the low speed compression adjuster knob and spool assembly. Remove the cable stop collar. Keep the parts together and set aside.



2 or 2.5 mm



RLC R / RCT R: 2 mm

Remove the cable stop collar. Remove the spool.



RL R / RC R: 2 or 2.5 mm



RL R / RC R: 2 or 2.5 mm

- 5** Remove the damper assembly.
Clean the upper tube threads.



Top Cap / Cassette Tool



24 mm

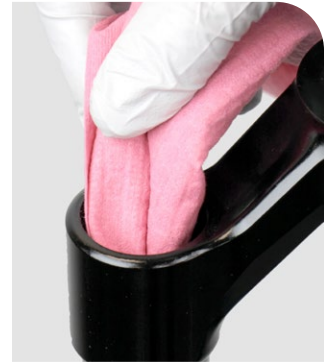

SID Continue with [Charger Race Day 2 Damper](#) or [Charger 2 RLC Damper](#) installation.

PIKE / REVELATION / LYRIK / YARI / ZEB Continue with [Charger 2.1 Damper](#) installation.

PIKE / REVELATION / LYRIK / YARI Continue with [Charger 2 RCT Remote Damper](#) installation.

Charger R Damper Removal (ZEB)

The procedure for removing the damper is similar across RockShox front suspension forks. Your fork's knobs, bolts, and damper may appear different from the pictures. Consult your fork's service manual for more detailed instructions.

ZEB A2: Refer to the 2023+ ZEB Lyrik Pike Service Manual for damper removal and installation procedures.

⚠ CAUTION

Place an oil pan on the floor underneath the product during service to catch any drained or spilled fluids. To avoid a slip and fall, and possible injury or harm, immediately clean any oil, fluid, grease, or lubricant from the floor in your work area.

- 1** Loosen the damper side bottom bolt 3 to 4 turns.
Strike the damper side bottom bolt to dislodge the shaft from the lower leg on the damper side. The bolt head should contact the bottom of the lower leg.
Remove the damper side bottom bolt. Clean it and set it aside.

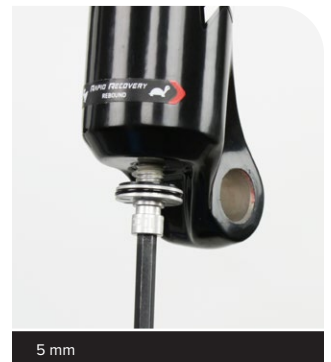
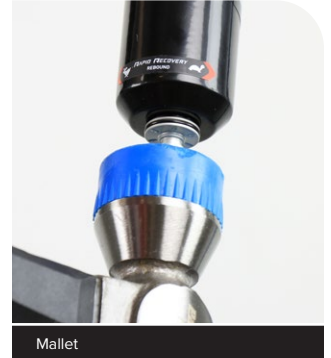
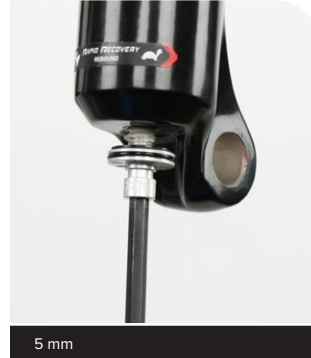

- 2** Unthread the damper top cap and remove the damper assembly.



Clean the upper tube threads.



 **ZEB** Continue with [Charger 2.1 Damper](#) installation.

Charger Damper RC and Charger 2 RC2 Removal (BOXXER)

BoXXer D1: Refer to the 2024+ BoXXer Service Manual for damper removal and installation procedures.

⚠ CAUTION

Place an oil pan on the floor underneath the product during service to catch any drained or spilled fluids. To avoid a slip and fall, and possible injury or harm, immediately clean any oil, fluid, grease, or lubricant from the floor in your work area.

- 1 BoXXer:** Refer to the 2019-2023 BoXXer Service Manual for procedures to remove the fork from the bicycle and upper crown removal.

Clamp the damper side upper tube into the bicycle work stand.



- 2** Loosen the damper side bottom bolt 3 to 4 turns.
Strike the damper side bottom bolt to dislodge the shaft from the lower leg on the damper side. The bolt head should contact the bottom of the lower leg.
Remove the damper side bottom bolt. Clean it and set it aside.
The lower leg does not need to be removed from the damper upper tube.

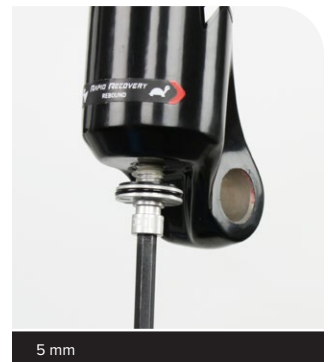
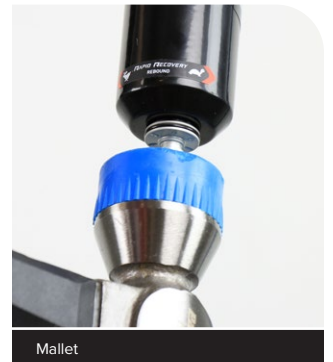
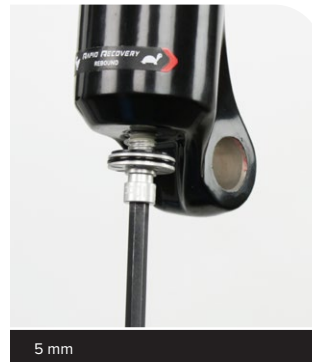

- 3 Charger RC:** Turn the compression adjuster knob counter-clockwise, to the full open position, until it stops.



4 **Charger RC:** Turn the compression adjuster knob counter-clockwise, to the full open position, until it stops.



5 **Charger RC:** Remove the retaining screw and remove the knob.

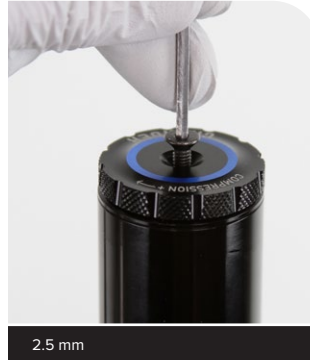

6 **Charger 2 RC2:** The compression damper must be in the full open position in order to perform the bleed procedure.

Turn the compression adjuster knobs counter-clockwise, to the full open position, until they stop.

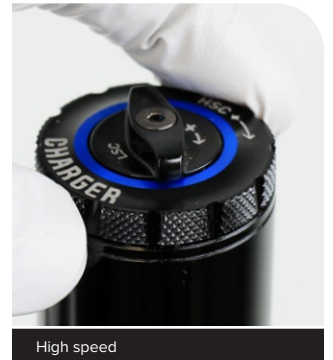
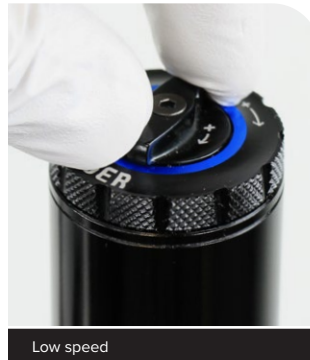

7 **Charger 2 RC2:** Remove the knob retaining screw.



- 8 Remove the low speed compression adjuster knob. Remove the high speed compression adjuster knob.

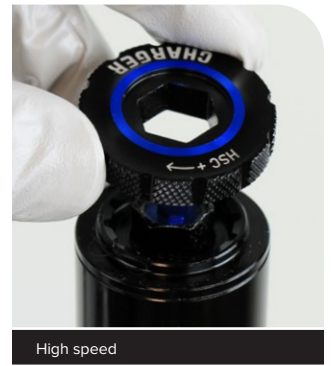

- 9 Unthread the damper top cap and remove the damper assembly.

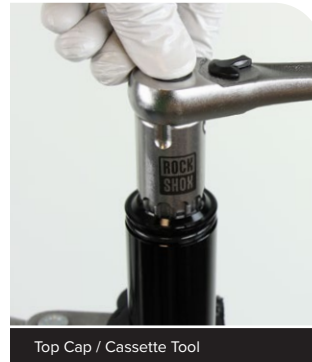

Clean the upper tube threads.

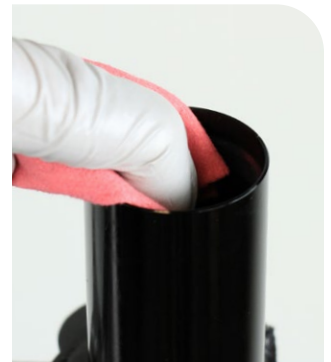

- BOXXER** Continue with [Charger 2.1 RC2 Damper](#) installation.

⚠ CAUTION

Place an oil pan on the floor underneath the product during service to catch any drained or spilled fluids. To avoid a slip and fall, and possible injury or harm, immediately clean any oil, fluid, grease, or lubricant from the floor in your work area.

- 1** Insert a 5 mm extension or hex wrench into the bolt head of the **damper side** lower leg. Strike the wrench to dislodge the shaft from the lower leg. The bolt head should contact the bottom of the lower leg. Remove the **damper side** bottom bolt. Clean the bolt and set it aside.

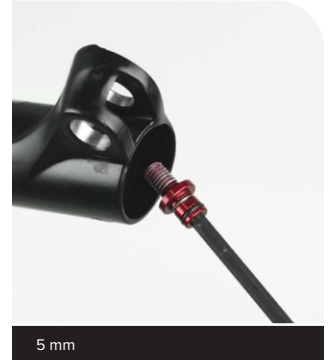
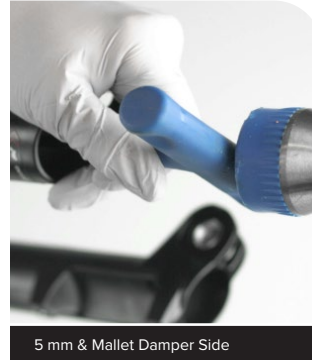

- 2 RL:** Turn the compression adjuster knob counter-clockwise, to the full open position, until it stops.



- 3 RL:** Remove the retaining screw and remove the knob. Remove the glide ring and o-ring. Clean the top cap grooves.

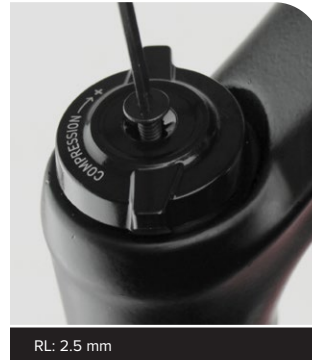

4 **RL R:** Loosen the set screw and remove the cable spool and cable stop collar.

Remove the glide ring. Clean the top cap grooves.



RL R: 2.5 mm



RL R



5 Unthread the damper top cap and remove the damper assembly. Clean the upper tube threads.



24 mm

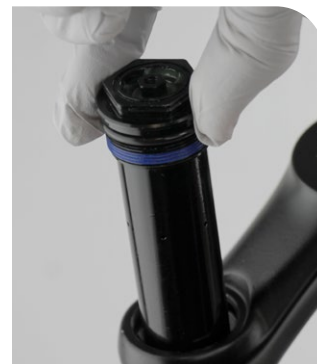

 **SID** Continue with [Charger Race Day 2 Damper](#) installation.

⚠ CAUTION

Place an oil pan on the floor underneath the product during service to catch any drained or spilled fluids. To avoid a slip and fall, and possible injury or harm, immediately clean any oil, fluid, grease, or lubricant from the floor in your work area.

- 1 Use a 10 mm socket and extension to remove the rebound nut on the **damper side** lower leg.

Insert a 5 mm hex wrench into the rebound damper shaft. Strike the wrench with the mallet to dislodge the shaft from the lower leg. Push the shaft into the lower leg.

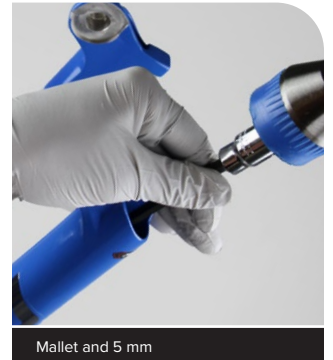

2 **RL:** Turn the lockout adjuster knob to the closed position. Loosen the screw.



RL Locked

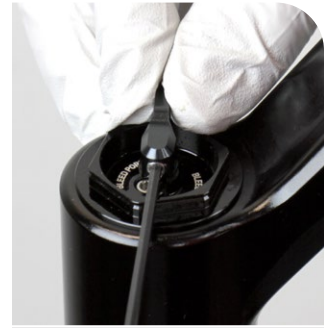

2 mm

RL: Turn the lockout adjuster knob to the open, unlocked position. Remove the knob.



RL Unlocked



RL

RL R: Loosen the remote spool screw and remove the remote spool.



RL R: 2 mm



RL R: Loosen the cable stop collar screw and remove the cable stop collar.



RL R: 1.5 or 2 mm



- 3** Remove the Charger Race Day Damper assembly.
Clean the upper tube threads.

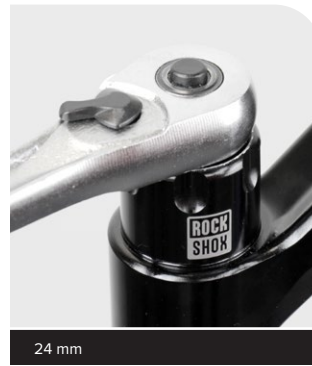

-  **SID** Continue with [Charger Race Day 2 Damper](#) installation.

⚠ CAUTION

Place an oil pan on the floor underneath the product during service to catch any drained or spilled fluids. To avoid a slip and fall, and possible injury or harm, immediately clean any oil, fluid, grease, or lubricant from the floor in your work area.

1 Ultimate / Select +: Use a 10 mm socket and extension to remove the rebound nut on the **damper side** lower leg.

Insert a 5 mm hex wrench into the rebound damper shaft. Strike the wrench to dislodge the shaft from the lower leg.

Push the shaft into the lower leg.

Discard the crush washer and rebound nut.



Ultimate / Select +: Damper Side - 10 mm



Ultimate / Select +: Damper Side - 5 mm

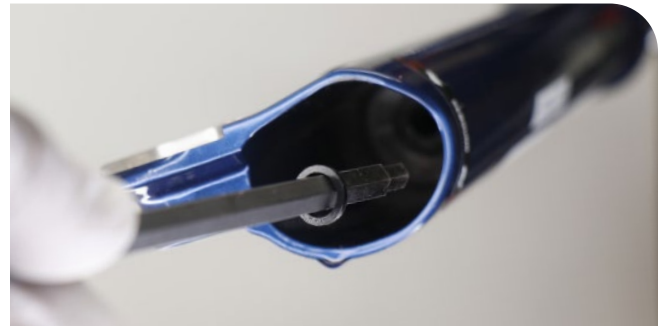

Ultimate / Select +: Damper Side - 5 mm

2 RL: Turn the lockout adjuster knob to the open, unlocked position. Remove the knob.



RL Unlocked



RL

Remove the detent plate. Loosen the adapter knob. Remove the adapter knob.



RL



2 mm

RL R: Loosen the remote spool screw and remove the remote spool.



RL R: 2 mm

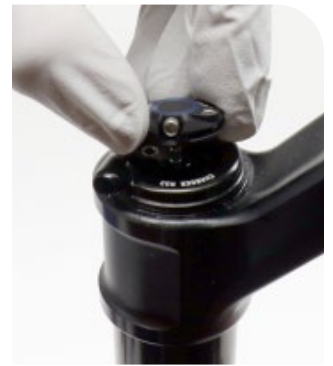

RL R: Loosen the cable stop collar screw and remove the cable stop collar.



RL R: 1.5 mm



3 Remove the Charger Race Day Damper 2 assembly.



24 mm



Clean the upper tube threads.



SID Continue with [Charger Race Day 2 Damper](#) installation.

NOTICE

The Maxle inserts are reverse threaded. To avoid damaging the fork when removing or installing Maxle inserts, carefully read the instructions and follow directional arrows. For additional detail, refer to the *RUDY XPLR Service Manual*.

CAUTION

Place an oil pan on the floor underneath the product during service to catch any drained or spilled fluids. To avoid a slip and fall, and possible injury or harm, immediately clean any oil, fluid, grease, or lubricant from the floor in your work area.

- 1 Use an 8 mm hex wrench to remove the Maxle insert from the spring side of the lower leg by rotating the insert **clockwise**.



- 2 Use an 11 mm hex wrench to remove the Maxle insert from the damper side of the lower leg by rotating the insert **clockwise**.

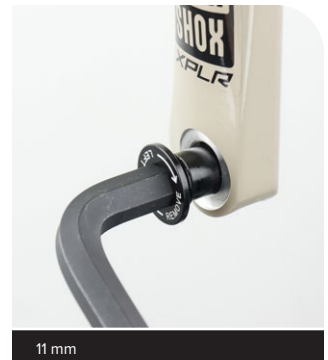

- 3 Remove the rebound housing bolt from the damper side of the lower leg.

Holding the fork horizontally to remove the rebound set screw will assist in removing the rebound assembly from the lower leg.



- 4 Remove the rebound mechanism from the damper side of the lower leg.

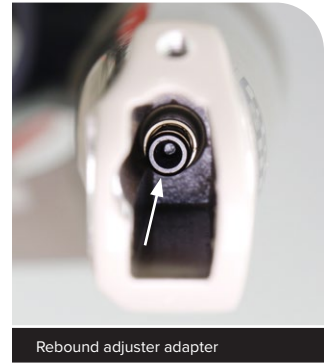

Remove the black rebound adjuster adapter from the rebound bottom nut. Check that the o-ring is around the rebound nut. If not, it may be resting on the bottom bolt; use a pick to remove it from the lower leg and install it on the rebound nut.

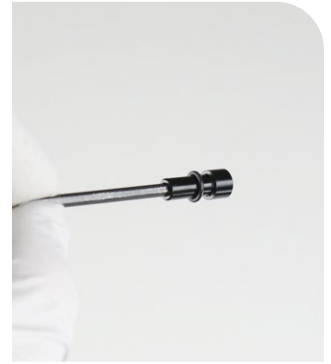

- 5 Use a 5 mm extension (minimum 110 mm length) to loosen the rebound bottom nut and bottom bolt 3 to 4 turns.



- 6 Insert a 5 mm extension or hex wrench (minimum 110 mm length) into the bolt head of the **spring side** lower leg. Strike the wrench to dislodge the shaft from the lower leg. The bolt head should contact the bottom of the lower leg.

Remove the **spring side** bottom bolt. Clean the bolt and set it aside.

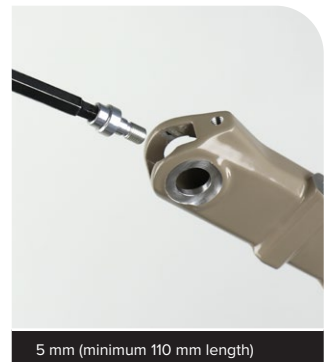

7 Insert a 5 mm hex wrench (minimum 110 mm length) into the **rebound bottom nut**. Strike the wrench to dislodge the shaft from the lower leg.

Remove the **rebound bottom nut**. Make sure the crush washer is either still in the rebound bottom nut or is no longer in the lower leg. Remove the crush washer if it is in the lower leg.

Clean the bolt and set it aside.



5 mm (minimum 110 mm length) & Mallet



5 mm (minimum 110 mm length)

8 Firmly pull the lower leg downward until fluid begins to drain. Continue pulling downward to remove the lower leg.

If the lower leg does not slide off of the upper tube or if oil does not drain from either side, the press fit of the shaft(s) into the lower leg may still be engaged. Reinstall the bottom bolt and bottom nut 2 to 3 turns and repeat the previous step.

NOTICE

Do not strike the fork arch with any tool when removing the lower leg as this could damage the lower leg.



9 Remove the damper cap.



10 Remove the damper assembly.



Top Cap / Cassette Tool



Clean the upper tube threads.



RUDY XPLR Continue with [Charger Race Day Damper \(RUDY XPLR\)](#) installation.

Charger 2 RLC Damper Installation (SID / REBA / BLUTO)

1 Clean the inside and outside of the upper tube.

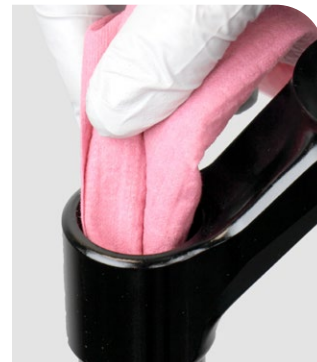

2 Install the Charger 2 Damper into the damper side upper tube.

NOTICE

To prevent scratching the rebound damper shaft, use your fingers to protect and guide the shaft as you install or remove the damper from the upper tube.



3 Install the top cap and tighten.



Top Cap /
Cassette Tool 28 N·m (250 in·lb)



24 mm 28 N·m (250 in·lb)

4 **RLC:** Install the lockout adjuster knob onto the top cap so the knob rotates from open to closed.

Install the low speed compression knob onto the lockout knob. Install and tighten the retention screw.



2 mm 1 N·m (9 in·lb)

5 RLC R: Install the cable stop collar with the cable guide in the forward position. Install the remote spool onto the hex adjuster with the cable set screw oriented within the 87° range zone.

Install and tighten the low speed compression knob screw.

Hand tighten the cable stop collar bolt, and then tighten it.

NOTICE

Do not overtighten the cable stop collar bolt. Overtightening the bolt may result in damage to the remote top cap and cause the cable to rub.

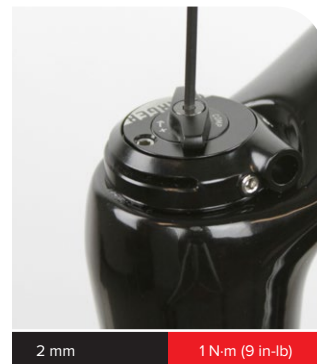
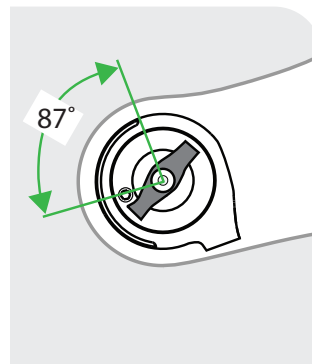

 Continue with [Lower Leg Assembly](#).

Charger 2 RCT Remote Damper Installation (PIKE / REVELATION / LYRIK / YARI)

Pike C1, Lyrik D1, ZEB A2: Refer to the 2023+ ZEB Lyrik Pike Service Manual for damper removal and installation procedures.

- 1 Clean the inside and outside of the upper tube.

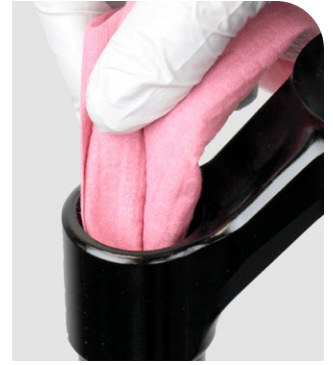

- 2 Install the Charger 2 RCT Remote damper into the damper side upper tube.

NOTICE

To prevent scratching the rebound damper shaft, use your fingers to protect and guide the shaft as you install or remove the damper from the upper tube.

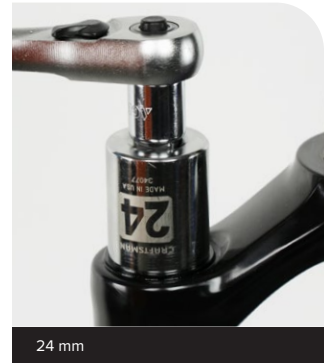

- 3 Tighten the top cap.



- 4 RCT R:** Install the cable stop collar with the housing guide in the 6 o'clock forward position, oriented outward ≈ 20 degrees from center.

NOTICE

The cable stop collar and remote cable housing must clear the lower leg arch when the fork is fully compressed.

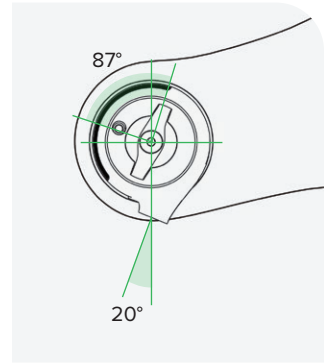

Push the low speed adjuster knob spring retainer (A) in and push the knob out of the remote spool.

Remove the top cap seal.

Clean each part.

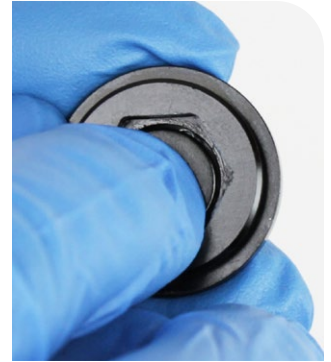
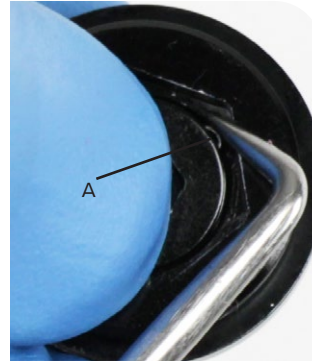

Install the remote spool onto the hex adjuster with the spool cable set screw oriented within the 87° range zone.

Install the knob seal.



Install the low speed adjuster knob onto the hex adjuster. Install and tighten the knob retaining screw.

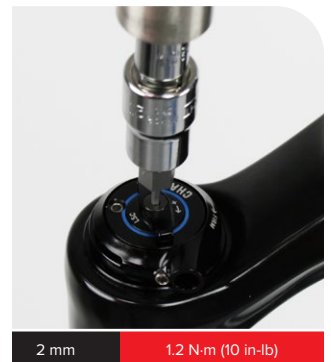

- 5** **RCT R / RC R:** Tighten the cable stop collar set screw.
Consult the applicable remote user manual at www.sram.com/rockshox/components/remotes for cable and remote installation instructions.



2 mm

0.4 N·m (4 in·lb)



2 mm

0.4 N·m (4 in·lb)

 Continue with [Lower Leg Assembly](#).

Pike C1, Lyrik D1, ZEB A2: Refer to the 2023+ ZEB Lyrik Pike Service Manual for damper removal and installation procedures.

- 1 Clean the inside and outside of the upper tube.

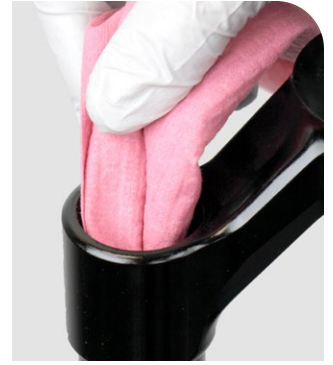

- 2 Install the Charger 2.1 Damper into the damper side upper tube.

NOTICE

To prevent scratching the rebound damper shaft, use your fingers to protect and guide the shaft as you install or remove the damper from the upper tube.

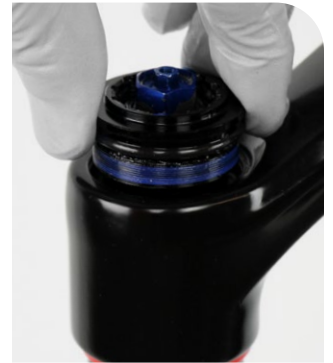

- 3 Install the top cap and tighten.



Top Cap / Cassette Tool

28 N·m (250 in-lb)

- 4 **RCT3:** Install the compression mode adjuster knob onto the top cap with the tab in the forward, unlocked position.



RCT3

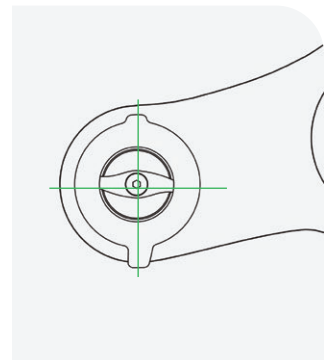

RC2: Install the high speed compression adjuster knob.



RC2 / RCT 3: Install the low speed compression adjuster knob onto the hex adjuster rod

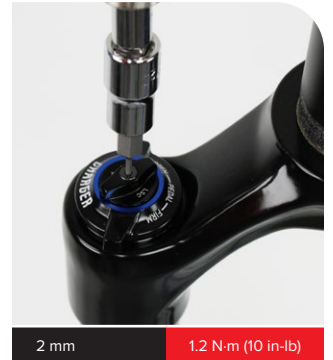

Install and tighten the retaining screw.

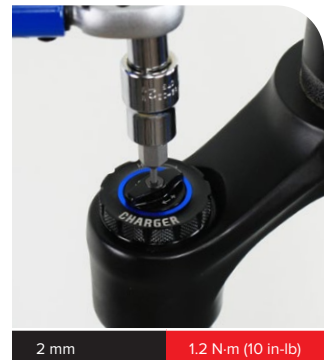
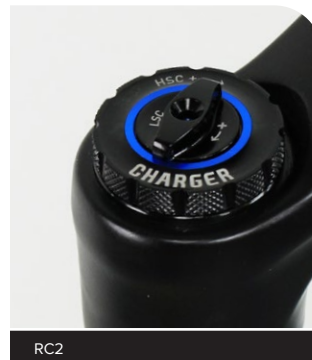

 Continue with [Lower Leg Assembly](#).

Charger 2.1 Damper RC2 Installation (BOXXER)

BoXXer D1: Refer to the 2024+ BoXXer Service Manual for damper removal and installation procedures.

- 1** Push the rebound damper shaft into the cartridge tube enough to leave room to inject oil into the lower leg.
Install the Charger 2.1 damper assembly into the damper side upper tube. Thread the top cap into the upper tube.

NOTICE

To prevent scratching the rebound damper shaft, use your fingers to protect and guide the shaft as you install or remove the damper from the upper tube.

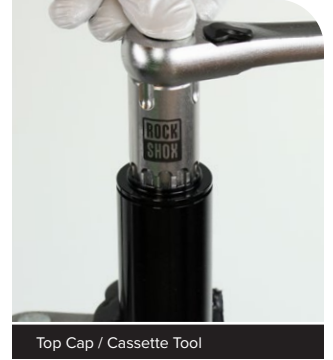

- 2** Tighten the top cap.



- 3** Install the high speed compression adjuster knob.
Install the low speed compression adjuster knob onto the hex adjuster rod.
Install and tighten the retaining screw.

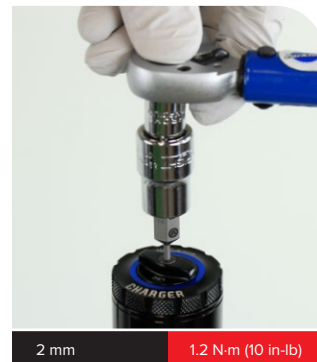

 Continue with [Lower Leg Assembly](#).

- 1 Clean the inside and outside of the upper tube.



- 2 Install the Charger Race Day 2 Damper into the damper side upper tube.

NOTICE

To prevent scratching the rebound damper shaft, use your fingers to protect and guide the shaft as you install or remove the damper from the upper tube.



- 3 Install the top cap and tighten.



24 mm

28 N-m (250 in-lb)

- 4 RL:** Position the detent plate with the cutouts placed in line with the fork crown. The 2P detent plate has two detents and the 3P has three. The controls install the same; they are not interchangeable.

NOTICE

To change from a 2P to a 3P damping system, you must replace the damper assembly. Consult the RockShox Spare Parts Catalog at www.sram.com/service for part numbers.

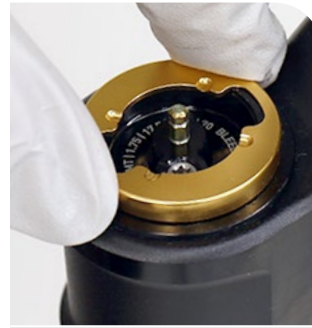

RL - 2P



RL - 3P

Install the adapter knob with the screw facing forward. Rotate the knob clockwise until it stops.



RL

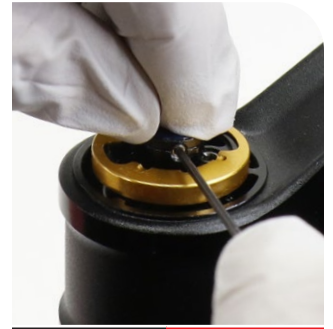

1.5 mm

0.3 N-m (3 in-lb)

Install the adjuster knob on the top cap so the flange is pointed away from the steerer tube. Rotate the adjuster knob clockwise until it stops on the last detent and the set screw is facing forward. Hold the knob down and tighten the set screw.



RL



1.5 mm

0.3 N-m (3 in-lb)

- 5 RL R:** Install the cable stop collar with the housing guide oriented forward. Tighten the set screw.

Install the remote spool with the set screw facing forward. Tighten the set screw.

NOTICE

The cable stop collar and remote cable housing must clear the lower leg arch when the fork is fully compressed.



1.5 mm

0.3 N-m (3 in-lb)



2 mm

0.3 N-m (3 in-lb)

 Continue with [Lower Leg Assembly](#).

Charger Race Day Damper Installation (RUDY XPLR)

- 1 Install the Charger Race Day Damper into the damper side upper tube.

NOTICE

To prevent scratching the rebound damper shaft, use your fingers to protect and guide the shaft as you install or remove the damper from the upper tube.



- 2 Install the top cap and tighten.



Top Cap / Cassette Tool

28 N·m (250 in·lb)

- 3 Install the adjuster knob with the tab in the 11 o'clock, unlocked position, then tighten the retaining screw. Check the adjuster knob to verify it rotates into the "Locked" position.



Ultimate



2 mm

0.4 N·m (3 in·lb)

Continue with [Lower Leg Installation \(RUDY XPLR\)](#).

Lower Leg Assembly

The procedure for installing the lower leg is similar across RockShox front suspension forks. Your fork's knobs, bolts, and chassis may appear different from the pictures. Consult your fork's service manual for more detailed instructions.

BoXXer: Refer to the *BoXXer Service Manual* for your fork model, for complete lower leg installation procedures.

Lower Leg Installation

- 1 Install the Schrader valve core into the top cap and tighten it finger tight.



RockShox Schrader valve tool

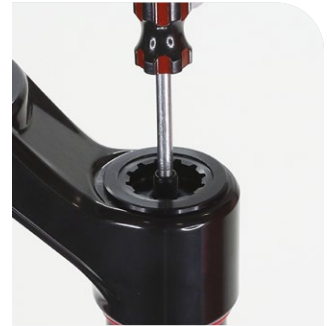

RockShox Schrader valve tool

- 2 Clean the upper tubes.
Proceed to step 5 if the lower leg is installed.

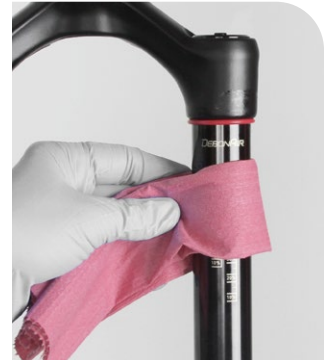
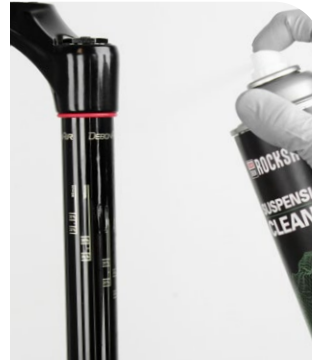

- 3 If the lower leg assembly was removed, apply grease to the inner surfaces of the wiper seals.



Grease (RockShox Dynamic Seal Grease or SRAM Butter)

- 4 If the lower leg assembly was removed, slide the lower leg onto the upper tube enough to engage the upper bushing with the upper tube.

NOTICE

Make sure both wiper seals slide onto the tubes without folding the outer lip of either seal.



The inside bottom of the lower leg should not contact the spring or damper shafts. A gap between the shaft ends and the lower leg bolt holes should be visible.



- 5 Position the fork at an angle with the lower leg bolt holes oriented upward.

Angle a syringe fitting in each lower leg bolt hole so the fluid will only contact the inside of the lower leg.

Inject the suspension oil into each lower leg through the lower leg bolt hole.

If the lower leg was not removed, inject suspension oil into the damper side only.

Consult the [Compatibility](#) section for fork lower leg oil and volume specifications. **Use the oil weight and volume for your fork model and year.**

NOTICE

Do not exceed the recommended oil volume per leg as this can damage the fork.



- 6 Slide the lower leg assembly toward the crown until it stops.

Verify each shaft is centered and seated in the lower leg shaft/bolt hole and no gap is visible between the lower leg and the shaft end.

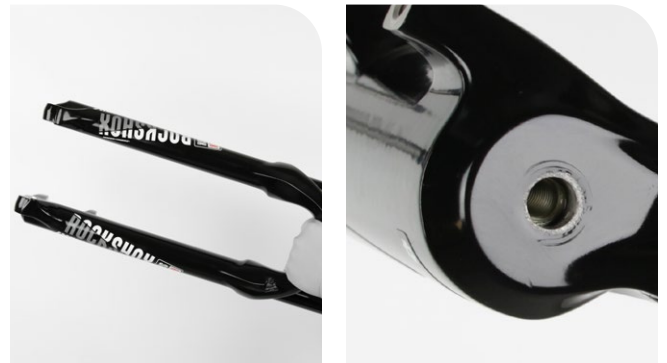

7 (SID / REBA / BLUTO) Charger Race Day 2 Damper Only : Use a 5 mm wrench to guide the shaft through the damper side bolt hole as you install the lower leg. Pull the damper shaft through the bolt hole so the threads are exposed.



Charger Race Day 2 Damper: 5 mm



Charger Race Day 2 Damper

(SID / REBA / BLUTO) Charger Race Day 2 Damper: Install the crush washer into the rebound adjuster nut. Install and tighten the rebound adjuster nut onto the **damper side** shaft of the lower leg.

⚠ WARNING - CRASH HAZARD

Parts must be tightened to the specified torque. Failure to do so can result in **SERIOUS INJURY OR DEATH**.



10 mm Damper Side



10 mm 8.4 N-m (74 in-lb)

8 Install the black bottom bolt into the spring side shaft of the lower leg. Install the hollow bottom bolt into the damper side shaft of the lower leg.

⚠ WARNING - CRASH HAZARD

Parts must be tightened to the specified torque. Failure to do so can result in **SERIOUS INJURY OR DEATH**.



5 mm 32 mm: 6.8 N-m (60 in-lb), 35 and 38 mm: 7.3 N-m (65 in-lb)



5 mm 32 mm: 6.8 N-m (60 in-lb), 35 and 38 mm: 7.3 N-m (65 in-lb)

9 Install the rebound damper knob.



Charger Race Day 2 Damper



Charger Race Day 2 Damper



Hollow Bottom Leg



Hollow Bottom Leg

Tighten the set screw, if present.

Do not over-tighten the set screw. Over-tightening will seize the adjuster knob and it will not turn.

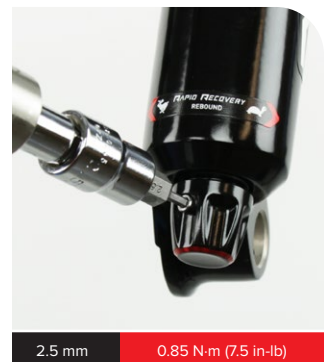

2.5 mm

0.85 N·m (7.5 in-lb)

10 Clean the entire fork.

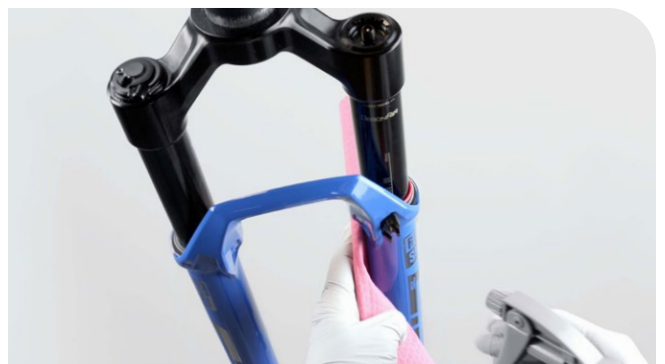

This concludes the Damper Upgrade on your RockShox suspension fork.

Lower Leg Installation (RUDY XPLR)

- 1 Install the Schrader valve core into the top cap and tighten it finger tight.



RockShox Schrader valve tool

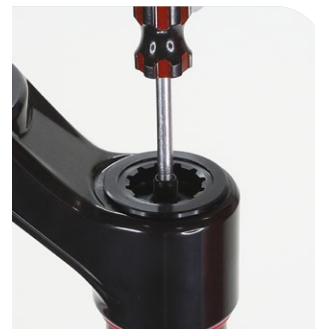

RockShox Schrader valve tool

- 2 Clean the upper tubes.

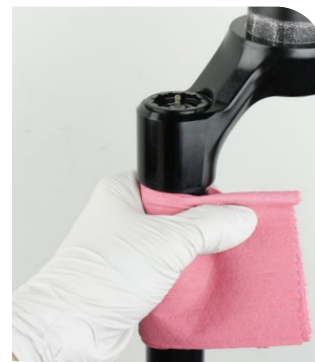

- 3 Apply grease to the inner surfaces of the wiper seals.
Wiper seals may already be greased from the factory. Do not apply extra grease to seals that already have grease on them.



Grease (RockShox Dynamic Seal Grease or SRAM Butter)

- 4 Hold the lower leg flat and inject 10 mL of suspension oil into each lower leg.

Keep the lower leg flat to prevent oil from leaking out.

NOTICE

Do not exceed the recommended oil volume per leg as this can damage the fork.



10 mL: Maxima PLUSH Dynamic Suspension Lube Heavy



10 mL: Maxima PLUSH Dynamic Suspension Lube Heavy

- 5** Orient the fork so that it is parallel to the ground.
Slide the lower leg onto the upper tube enough to engage the upper bushing with the upper tube.

NOTICE

Make sure both wiper seals slide onto the tubes without folding the outer lip of either seal.



- 6** Slide the lower leg assembly along the upper tubes until it stops and the spring and damper shafts are visible through the lower leg bolt holes.

Use a pick or small, long hex wrench to guide the shaft through the damper side bolt hole as you install the lower leg. Continue to install the lower leg until the shaft is through the bolt hole.

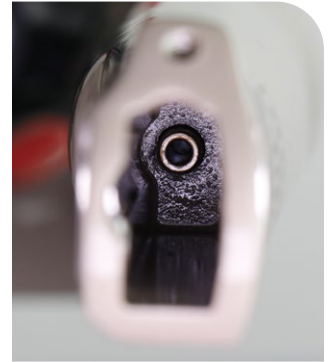

- 7** Use a pick and needle nose pliers to remove the crush washer from the rebound bottom nut and spring bottom bolt.

Discard and install a new crush washer.

NOTICE

Dirty or damaged crush washers can cause oil to leak from the fork.

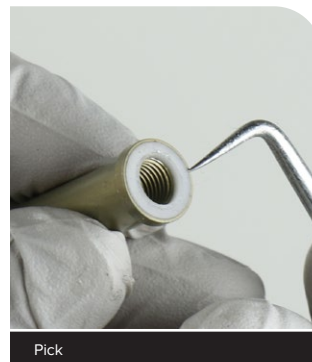

Pick

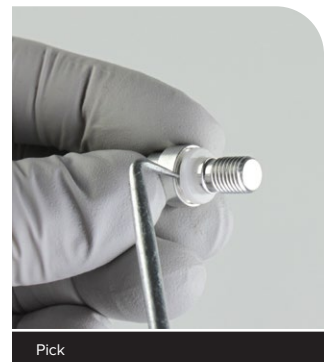

Pick

8 Install the silver bottom bolt into the **spring side** shaft of the lower leg.

⚠ WARNING - CRASH HAZARD

Parts must be tightened to the specified torque. Failure to do so can result in **SERIOUS INJURY OR DEATH**.

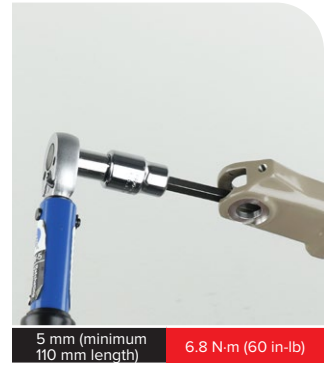

Install the rebound bottom nut into the **damper side** shaft of the lower leg. Be careful not to push the damper shaft back through the bolt hole.

⚠ WARNING - CRASH HAZARD

Parts must be tightened to the specified torque. Failure to do so can result in **SERIOUS INJURY OR DEATH**.

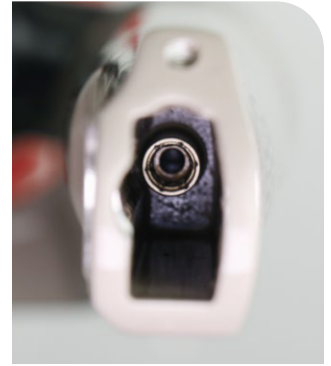

9 Install the rebound mechanism into the damper side lower leg, making sure to fully seat the rebound adjuster adapter into the bottom nut.



Use a 2.5 mm hex wrench or the Rebound Adjuster to hold the rebound mechanism against the lower leg, align the bolt holes, and install the rebound housing bolt.

Refer to your pre-service recorded rebound setting to adjust the rebound.



NOTICE

The Maxle inserts are reverse threaded. To avoid damaging the fork when removing or installing Maxle inserts, carefully read the instructions and follow directional arrows. For additional detail, refer to the *RUDY XPLR Service Manual*.

- 10** Use an 8 mm hex socket to install the Maxle insert into the spring side of the lower leg by rotating the insert **counter-clockwise** and tighten.

⚠ WARNING - CRASH HAZARD

Parts must be tightened to the specified torque. Failure to do so can result in **SERIOUS INJURY OR DEATH**.

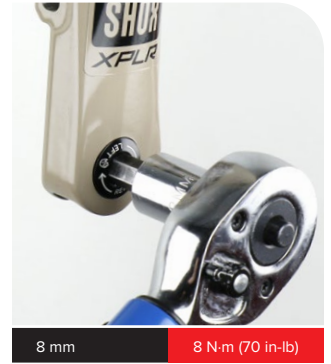

Use an 11 mm hex socket to install the Maxle insert into the damper side of the lower leg by rotating the insert **counter-clockwise** and tighten.

⚠ WARNING - CRASH HAZARD

Parts must be tightened to the specified torque. Failure to do so can result in **SERIOUS INJURY OR DEATH**.



This concludes the Damper Upgrade on your RockShox suspension fork.



ASIAN HEADQUARTERS

SRAM Taiwan
No. 1598-8 Chung Shan Road
Shen Kang Hsiang, Taichung City
Taiwan

WORLD HEADQUARTERS

SRAM, LLC
1000 W. Fulton Market, 4th Floor
Chicago, Illinois 60607
U.S.A.

EUROPEAN HEADQUARTERS

SRAM Europe
Paasbosweg 14-16
3862ZS Nijkerk
Niederlande