

ZIPP

ZM2 Hubs



SERVICE MANUAL

SRAM® LLC WARRANTY

THIS WARRANTY GIVES YOU SPECIFIC LEGAL RIGHTS AGAINST SRAM, LLC. YOU MAY ALSO HAVE OTHER RIGHTS THAT VARY FROM STATE TO STATE, COUNTRY, OR PROVINCE. THIS WARRANTY DOES NOT AFFECT YOUR STATUTORY RIGHTS. TO THE EXTENT THIS WARRANTY IS INCONSISTENT WITH THE LOCAL LAW, THIS WARRANTY SHALL BE DEEMED MODIFIED TO BE CONSISTENT WITH SUCH LAW. FOR A FULL UNDERSTANDING OF YOUR RIGHTS, CONSULT THE LAWS OF YOUR COUNTRY, PROVINCE, OR STATE.

THIS WARRANTY APPLIES TO SRAM PRODUCTS MADE UNDER THE SRAM®, ROCKSHOX®, TRUVATIV®, ZIPP®, QUARG®, AVID® AND TIME® BRAND NAMES.

EXTENT OF LIMITED WARRANTY

Except as otherwise set forth herein, SRAM warrants its bicycle components to be free from defects in materials or workmanship for a period of two (2) years after original purchase of the product.

SRAM warrants all Zipp MOTO Wheels and Rims to be free from defects in materials or workmanship for the lifetime of the product.

SRAM warrants all non-electronic Zipp branded bicycle components, Model Year 2021 or newer, to be free from defects in materials or workmanship for the lifetime of the product.

GENERAL PROVISIONS

This warranty only applies to the original owner and is not transferable. Claims under this warranty must be made through the retailer where the bicycle or the SRAM product was purchased or a SRAM authorized service location. Original proof of purchase is required. All SRAM warranty claims will be evaluated by a SRAM authorized service location whereupon acceptance of the claim the product will be repaired, replaced, or refunded at SRAM's discretion. To the extent allowed by local law claims under this warranty must be made during the warranty period and within one (1) year following the date on which any such claim arises.

NO OTHER WARRANTIES

EXCEPT AS DESCRIBED HEREIN, AND TO THE EXTENT ALLOWED BY LOCAL LAW, SRAM MAKES NO OTHER WARRANTIES, GUARANTIES, OR REPRESENTATIONS OF ANY TYPE (EXPRESS OR IMPLIED), AND ALL WARRANTIES (INCLUDING ANY IMPLIED WARRANTIES OF REASONABLE CARE, MERCHANTABILITY, OR FITNESS FOR A PARTICULAR PURPOSE) ARE HEREBY DISCLAIMED.

LIMITATIONS OF LIABILITY

EXCEPT AS DESCRIBED HEREIN, AND TO THE EXTENT PERMITTED BY LAW, IN NO EVENT SHALL SRAM OR ITS THIRD PARTY SUPPLIERS BE LIABLE FOR DIRECT, INDIRECT, SPECIAL, INCIDENTAL, OR CONSEQUENTIAL DAMAGES. SOME STATES (COUNTRIES AND PROVINCES) DO NOT ALLOW THE EXCLUSION OR LIMITATION OF INCIDENTAL DAMAGES, SO THE ABOVE LIMITATION MAY NOT APPLY TO YOU.

LIMITATIONS OF WARRANTY

This warranty does not apply to products that have been incorrectly installed, adjusted, and/or maintained according to the respective SRAM user manual. The SRAM user manuals can be found online at sram.com/service.

This warranty does not apply to damage to the product caused by a crash, impact, abuse of the product, non-compliance with manufacturer's specifications of intended usage, or any other circumstances in which the product has been subjected to forces or loads beyond its design.

This warranty does not apply when the product has been modified, including but not limited to, any attempt to open or repair any electronic and electronic related components, including the motor, controller, battery packs, wiring harnesses, switches, and chargers.

This warranty does not apply when the serial number or production code has been deliberately altered, defaced, or removed.

SRAM components are designed for use only on bicycles that are pedal powered or pedal assisted (e-Bike/Pedelec).

Notwithstanding anything else set forth herein, the battery pack and charger warranty does not include damage from power surges, use of improper charger, improper maintenance, or such other misuse.

This warranty shall not cover damages caused by the use of parts of different manufacturers or parts that are not compatible or suitable for use with SRAM components.

This warranty shall not cover damages resulting from commercial (rental) use.

WEAR AND TEAR

This warranty does not apply to normal wear and tear. Wear and tear parts are subject to damage as a result of normal use, failure to service according to SRAM recommendations, and/or riding or installation in conditions or applications other than recommended.

WEAR AND TEAR PARTS INCLUDE:

- | | | | |
|-----------------------|-----------------------------------|--|---|
| • Aero bar pads | • Chains | • Jockey wheels | • Sprockets |
| • Air sealing o-rings | • Cleats | • Rear shock mounting | • Stripped threads/bolts (aluminum, titanium, magnesium or steel) |
| • Batteries | • Corrosion | • Rubber moving parts | • Tires |
| • Bearings | • Disc brake rotors | • Shifter and Brake cables (inner and outer) | • Tools |
| • Bottomout pads | • Dust seals | • Shifter grips | • Transmission gears |
| • Brake pads | • Free hubs, Driver bodies, Pawls | • Spokes | • Upper tubes (stanchions) |
| • Bushings | • Foam rings, Glide rings | | • Wheel braking surfaces |
| • Cassettes | • Handlebar grips | | |

ZIPP IMPACT REPLACEMENT POLICY

Zipp branded products, Model Year 2021 or newer, are covered under a lifetime impact-damage replacement policy. This policy can be used to obtain a replacement of a product in the event of non-warranty impact damage occurring while riding your bicycle. See www.zipp.com/support for more information.

TABLE OF CONTENTS

ZIPP SERVICE	5
PART PREPARATION	5
SERVICE PROCEDURES	5
RIM AND WHEEL BUILDING SPECIFICATIONS	5
REAR HUB SERVICE	6
COMPONENT REMOVAL	6
PARTS, TOOLS, AND SUPPLIES	6
EXPLODED VIEW - REAR HUB	7
REAR HUB END CAPS	7
REAR HUB BEARING REMOVAL	8
REAR HUB BEARING INSTALLATION	12
DRIVER CLEANING (OPTIONAL) - COIL SPRING DRIVER	16
DRIVER CLEANING (OPTIONAL) - LEAF SPRING DRIVER	19
DRIVER BEARING REPLACEMENT (OPTIONAL)	21
FRONT HUB SERVICE	23
COMPONENT REMOVAL	23
PARTS, TOOLS, AND SUPPLIES	23
EXPLODED VIEW - FRONT HUB	24
FRONT HUB END CAPS	24
FRONT HUB BEARING REMOVAL	25
FRONT HUB BEARING INSTALLATION	28



SAFETY FIRST!

We care about YOU. Please, always wear your safety glasses and protective gloves when servicing SRAM® products.

Protect yourself! Wear your safety gear!

Zipp Service

We recommend that you have your Zipp components serviced by a qualified bicycle mechanic. Servicing Zipp components requires the use of specialized tools. Failure to follow the procedures outlined in this service manual may cause damage to your component and void the warranty.

Visit www.zipp.com/support for the latest Zipp Spare Parts catalog and technical information. For order information, please contact your local Zipp distributor or dealer.

Information contained in this publication is subject to change at any time without prior notice.

Your product's appearance may differ from the pictures contained in this publication.



For recycling and environmental compliance information, please visit www.sram.com/company/environment.

Part Preparation

Remove the component from the bicycle before service.

Clean the exterior of the product with mild soap and water to avoid contamination of internal sealing part surfaces.

Service Procedures

The following procedures should be performed throughout service, unless otherwise specified.

Clean the part with isopropyl alcohol and a clean, lint-free shop towel.

Clean the sealing surface on the part and inspect it for scratches.

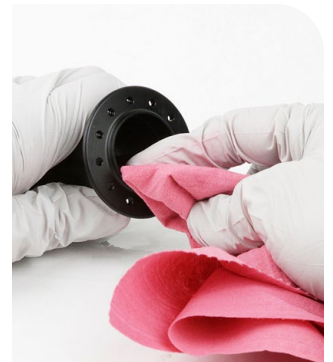

Rim and Wheel Building Specifications

For spoke lengths, tension, rim ERD, hub dimensions, and technical specifications, please refer to the Zipp Wheel Specifications document available at sram.com/service.

Component Removal

Prior to service, remove the wheels from the bicycle according to the bicycle manufacturer's instructions and thoroughly clean the exterior of the product to avoid contamination of internal sealing part surfaces.

For additional information about Zipp wheels and hubs, user manuals are available at www.Zipp.com.

Parts, Tools, and Supplies

Parts

- WHEEL BEARING KIT FRONT/REAR FOR ZIPP ZR1/ZM2 HUBS, 61903
- WHEEL FREEHUB KIT - ZIPP ZM2 XD (optional)
- WHEEL FREEHUB KIT - ZIPP ZM2 10 SPD (optional)

Safety and Protection Supplies

- Apron
- Clean, lint-free shop towels
- Nitrile gloves
- Safety glasses

Lubricants and Fluids

- Isopropyl alcohol
- Zipp Cognition or Klüber Staburags NBU30 grease
- SRAM Butter grease

Zipp/SRAM Tools

- Zipp 61903 Bearing Press Tool (x2)
or
Zipp 61903 Bearing Press Tool (x1) *and*
SRAM 6903 Bearing Press Tool (x1)

Bicycle Tools

- Axle and Spindle Vise Inserts - Park Tool AV-4 or AV-5
- Blind Hole Bearing Puller Set
 - 17 mm slotted attachment
- Wheels Manufacturing Press-1 Sealed Bearing Press Kit or similar
 - 6903 30x17 bearing press adapters (x2)
 - 6803 26x17 bearing press adapters (x2) (optional)
 - T-handle threaded bearing press

Common Tools

- Bench vise
- Flat blade screwdriver
- Needle-nose pliers
- Grease brush
- Rubber or plastic mallet
- Vise soft jaws (aluminum)

SAFETY INSTRUCTIONS

Always wear nitrile gloves when working with bicycle grease.

Exploded View - Rear Hub

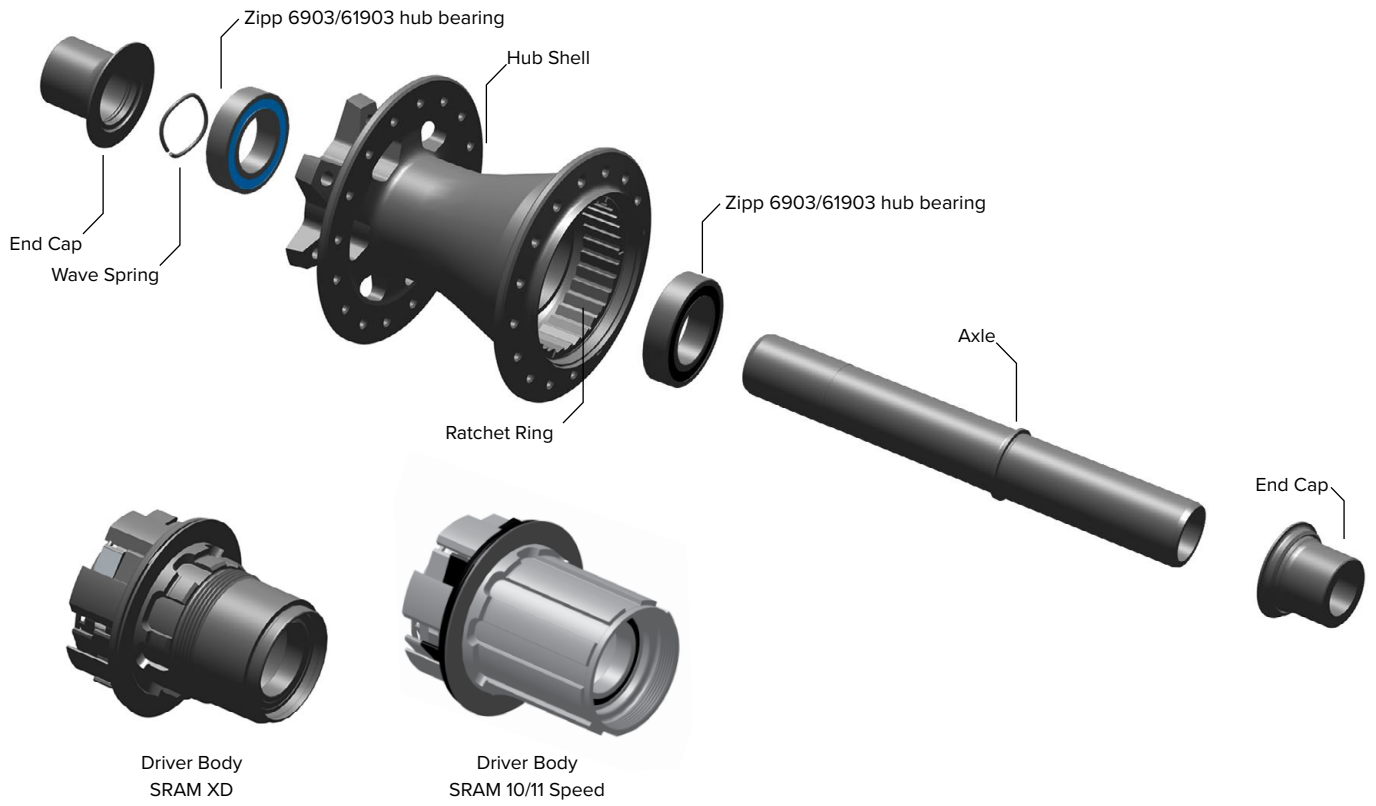

Rear Hub End Caps

Hub	Variants				DRIVE SIDE			NON DRIVE SIDE		
					Current Identification Text On End Cap	Previous Identification Text On End Cap	Spare Part Kit Number	Current Identification Text On End Cap	Previous Identification Text On End Cap	Spare Part Kit Number
ZM2	REAR	12 X 148	6B	10SPD XD	151-030	12x(142/148) DS XD(R)	11.2018.064.007	212-000	—	11.2018.064.007

Rear Hub Bearing Removal

Procedures are the same for rim brake and disc brake rear hubs. Disc brake hub pictured.

- 1 Insert the Park Tool AV-4 or AV-5 Axle and Spindle Vise Insert tool into a vise. Clamp one end cap into the vise insert tool and pull up on the wheel/hub to remove the end cap.
Repeat to remove the other end cap.



- 2 Pull the driver body from the hub by hand.



- 3 Inspect the rubber seal for damage. If the seal is damaged, replace the driver body.



- 4 Use a plastic mallet to tap the non-drive side end of the axle to remove the axle and bearing from the hub.

Pull the axle and drive side bearing out of the drive side of the hub.

If the drive side bearing was not removed with the axle, it must be removed with the Bearing Puller tool as instructed in step 7.



5 The wave spring installed on the non-drive side of the axle will slide off when the axle is removed. Set the wave spring aside.

NOTICE

Do not discard or misplace the wave spring. It is crucial to hub performance and the hub will not function properly without the spring.



6 **Note:** If the drive side bearing is not removed with the axle, a bearing puller must be used to remove the bearing from the hub.

Place the axle in between flat aluminum vise soft jaws, drive side down, with the bearing resting on top of the soft jaws. Make sure the axle bearing step does not contact the soft jaws. Use a plastic mallet to gently tap on the top of the non-drive end of the axle until it is dislodged from the bearing. Discard the bearing.

NOTICE

To avoid damage to the axle, do not allow the axle to contact the vise soft jaws. If the axle bearing step is damaged, the axle must be replaced.

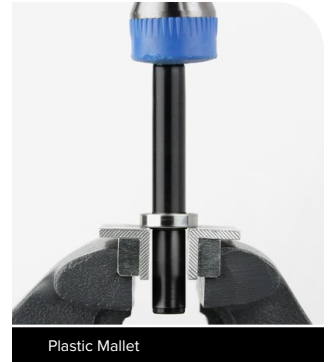

7 Clean the axle with isopropyl alcohol and a shop towel.

NOTICE

To prevent damage to the hub surfaces, do not use acetone or similar products to clean parts.



8 Insert the 17 mm Bearing Puller slotted attachment through the drive side bearing. Align the slotted attachment with the bottom of the bearing, and expand it inside the bearing.

Do not over tighten the slotted attachment. For more detailed assembly and usage, see the bearing puller manufacturer's instructions.

Grip the slide hammer and forcefully pull away from the slotted attachment to remove the bearing from the driver body.



17 mm Slotted Attachment



9 Insert the 17 mm Bearing Puller slotted attachment through the non-drive side bearing. Align the slotted attachment with the bottom of the bearing, and expand it inside the bearing.

Do not over tighten the slotted attachment. For more detailed assembly and usage, see the bearing puller manufacturer's instructions.

Grip the slide hammer and forcefully pull away from the slotted attachment to remove the bearing from the driver body.



17 mm Slotted Attachment

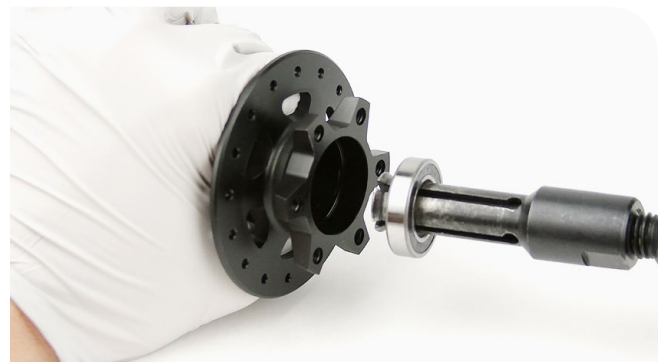

10 Clean the bearing bores with isopropyl alcohol and a shop towel.



11 Clean the ratchet ring and hub internals with isopropyl alcohol, a shop towel, and cotton swabs. Do not remove the ratchet ring.



NOTICE

To prevent damage when pressing the bearings into the rear hub, make sure that the bearing press tool contacts both the inner and outer races of the bearing.

- 1 Install a new Zipp 6903/61903 hub bearing into the non-drive side of the hub with the **black** seal facing outward.

Note: Ceramic bearings have **blue** seals on both sides of the bearing; installation orientation is not important.

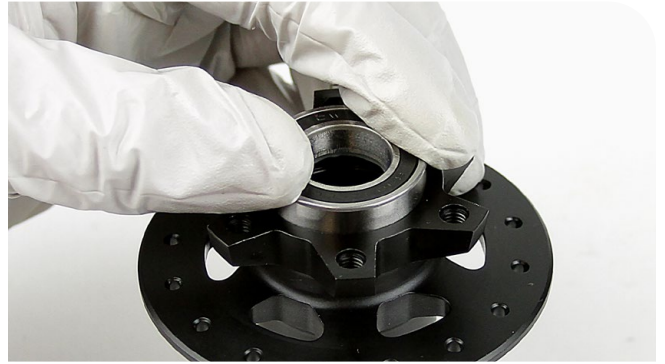

- 2 Install a 6903 30x17 tool into the drive-side bearing bore.

Insert the threaded rod through the drive side of the hub shell. Slide a second 6903 30x17 tool onto the threaded rod.

Thread the Press Tool handle onto the threaded rod.

Turn the handle clockwise to press the bearing into the hub until it is hand-tight.

Do not overtighten the bearing.

Remove the tools.



6903 30x17



6903 30x17

NOTICE

To prevent damage when pressing the bearing into the hub, make sure that the bearing press tools contact both the inner and outer bearing races or bearing bores and not the hub shell.

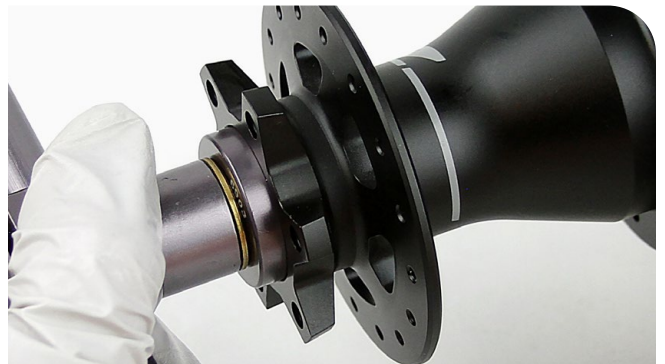

- 3 Install a new bearing onto the longer, non-drive side of the axle, with the **blue** bearing seal facing away from the raised step on the axle.

Note: Ceramic bearings have **blue** seals on both sides of the bearing; installation orientation is not important.

Insert the non-drive side of the axle into a Zipp 61903 tool, with the flat, non-stepped end of the tool against the bearing.



Zipp 61903

- 4** Use a rubber or plastic mallet to tap the drive side of the axle until the raised step on the axle contacts the bearing
Remove the axle from the tool.



- 5** Insert a SRAM 6903 tool into the non-drive side bearing bore with the flat, non-stepped end of the tool against the bearing.
Install the non-drive side end of the axle through the hub and into the SRAM 6903 tool.



- 6** Install a Zipp 61903 tool onto the drive side end of the axle with the stepped end of the tool contacting the bearing.



- 7** Use a rubber mallet to tap the drive side of the axle until the raised step on the axle contacts the bearing
Remove the tool from the axle.

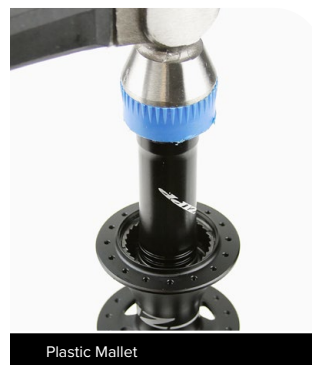

- 8** Apply grease to the ratchet ring (a) and the seal surface (b) of the hub shell.

NOTICE

If a brush is used to apply grease, confirm there are no loose bristles in the grease or on the part.

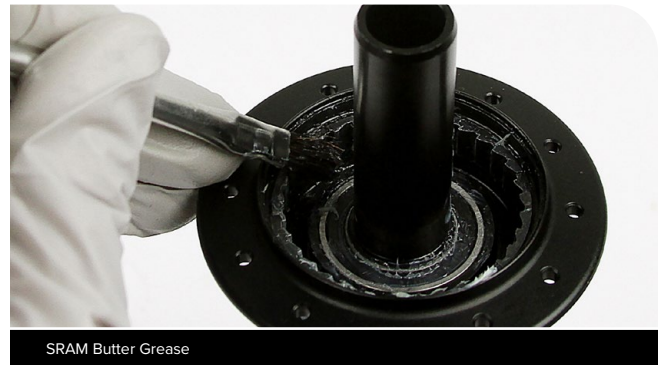

- 9** Apply grease to the last 10-15mm of the axle. Installation of the driver body will distribute the grease on the entire hub axle.

NOTICE

If a brush is used to apply grease, confirm there are no loose bristles in the grease or on the part.



- 10** Install the driver body onto the axle and twist it counter-clockwise to seat the driver body and driver body seal.

Make sure the driver body seal is fully seated into the seal groove.

The installation process is the same for 10 speed and XD driver bodies.



- 11** Install the wave spring onto the non-drive side of the axle. You may need a tool to press the wave spring against the bearing face.

NOTICE

Do not scratch the axle when using a tool to install the wave spring.

The wave spring is crucial to hub performance and must be installed onto the axle.

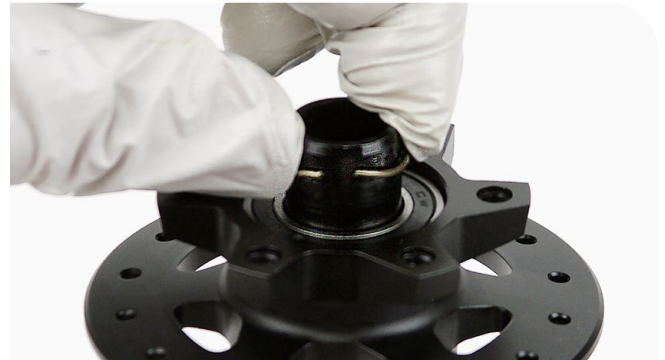

12 Apply grease to the following locations on the drive side and non-drive side axle end:

- Axle front surface (a)
- Axle radial surface (b)
- Bearing front face across bearing seal, inner- and outer ring (c)

NOTICE

If a brush is used to apply grease, confirm there are no loose bristles in the grease or on the part.

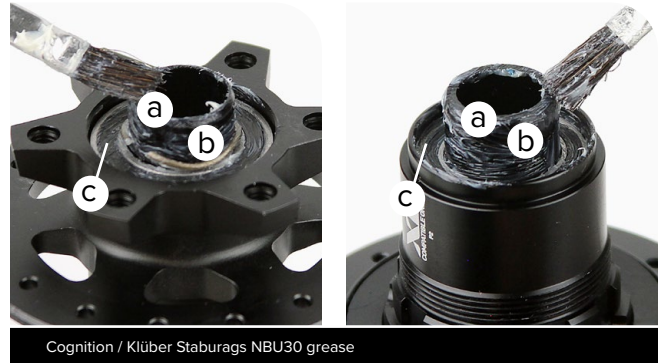

13 Press the end caps onto the axle.



14 Clean the hub with isopropyl alcohol and a shop towel.



NOTICE

Service of an 11 speed driver is identical to the XDR driver service shown below.

- 1 Inspect the rubber seal for damage. If the seal is damaged, replace the driver.



- 2 Use your fingers or a small flat blade screwdriver to lift the snap ring from the driver.



- 3 Use your fingers, a pick, or needle-nose pliers to remove the pawls and coil springs from the driver.

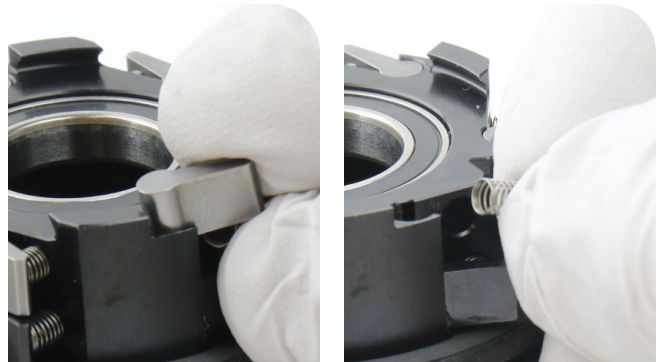

- 4 Clean the pawl slots with a cotton swab and the driver body with isopropyl alcohol and a shop towel.



- 5** Using a grease syringe, apply a small amount of SRAM Butter grease to the pawl slots.



- 6** Insert a coil spring into one of the lower spring slots, then install a **black** pawl into the pawl slot.
Note: The springs and pawls are symmetrical and can be installed in any orientation.



- 7** Use a small flat blade screwdriver to compress the spring to allow the pawl to drop into the slot, then adjust the spring so that it is perpendicular to the back of the pawl.

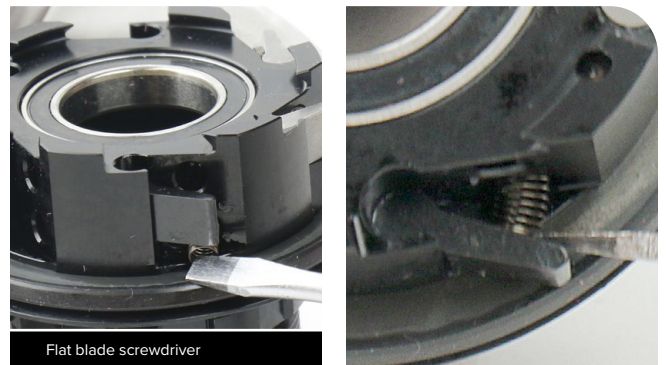

- 8** Insert a coil spring into the upper spring slot above the previously installed pawl/spring, then install a **silver** pawl into the pawl slot.
Note: The springs and pawls are symmetrical and can be installed in any orientation.



9 Use a small flat blade screwdriver to compress the spring to allow the pawl to drop into the slot, then adjust the spring so that it is perpendicular to the back of the pawl.

Repeat steps 6-9 to install the other springs and pawls.

Make sure the black pawls are installed in the lower row of slots.



10 Orient the end of the snap ring into the hole in the driver and push the snap ring onto the channel of the driver until it is fully seated.



NOTICE

Service of an 11 speed driver is identical to the XDR driver service shown below.

- 1 Inspect the rubber seal for damage. If the seal is damaged, replace the driver.



- 2 Use a small flat blade screwdriver to lift the snap ring from the driver.



- 3 Use a pick or needle-nose pliers to remove the pawls and leaf springs from the driver.

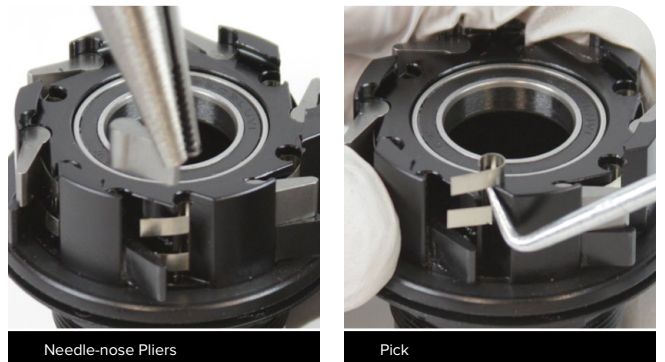

- 4 Using a grease syringe, apply a small amount of SRAM Butter grease to the pawl slots.



- 5** Insert the leaf springs into the spring slots. Orient the long edge of each spring along the inside of the carrier so that it points clockwise.

NOTICE

Do not force the spring into the slot; it should slide in easily. Forcing the spring into the slot can bend or damage the spring requiring replacement of the driver.

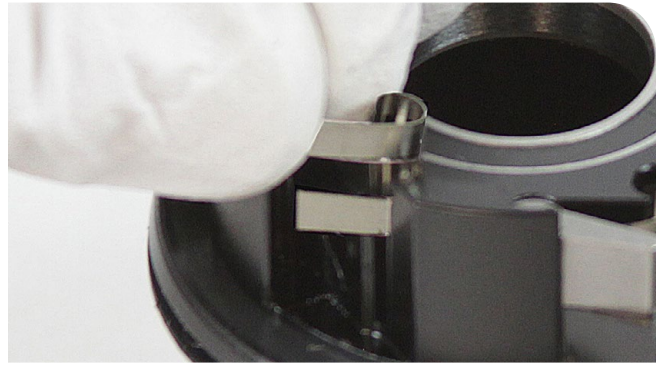

- 6** Insert the black pawls into the pawl slots followed by the silver pawls. Use a pick or flat blade screwdriver to compress each leaf spring to assist with inserting the pawls.



Pick

- 7** Orient the end of the snap ring into the hole in the driver and push the snap ring onto the channel of the driver until it is fully seated.



NOTICE

Service of a 10 speed driver is identical to the XD driver service shown below.

- 1 Insert the 17 mm Bearing Puller slotted attachment through the outboard bearing. Align the slotted attachment with the bottom of the bearing, and expand it inside the bearing.

Do not over tighten the slotted attachment. For more detailed assembly and usage, see the bearing puller manufacturer's instructions.

Thread the rod of the bearing puller into the attachment. Grip the slide hammer and forcefully pull away from the slotted attachment to remove the bearing from the driver body.



- 2 Insert the 17 mm Bearing Puller slotted attachment through the inboard bearing. Align the slotted attachment with the bottom of the bearing and expand it inside the bearing.

Do not over tighten the slotted attachment. For more detailed assembly and usage, see the bearing puller manufacturer's instructions.

Thread the rod of the bearing puller into the attachment. Grip the slide hammer and forcefully pull away from the slotted attachment to remove the bearing from the driver body.



- 3 Clean the driver bearing bores with a shop towel and cotton swabs.



- 4 Place the driver on flat surface, outboard side up. Insert a new Zipp 6803/61803 driver bearing into the outboard side of the driver body, with the **black** seal facing outward.

Note: Ceramic bearings have **blue** seals on both sides of the bearing; installation orientation is not important.

Insert a 6803 26x17 tool onto the bearing.



5 Insert the threaded rod through the bearing on the outboard side of the driver. Slide a second 6803 26x17 tool onto the threaded rod.

Thread the Press Tool handle onto the threaded rod.

Turn the handle clockwise to press the bearing into the driver body until it is hand-tight.

Do not overtighten the bearing.

Remove the tools.

NOTICE

To prevent damage when pressing the bearing into the driver body, make sure that the bearing press tools contact both the inner and outer bearing races or bearing bores and not the driver body.



6 Place the driver on a flat surface, inboard side up. Insert a new Zipp 6803/61803 driver bearing into the inboard side of the driver body, with the **black** seal facing outward.

Note: Ceramic bearings have **blue** seals on both sides of the bearing; installation orientation is not important.

Insert a 6803 26x17 tool onto the bearing.



7 Insert the threaded rod through the bearing on the inboard side of the driver. Slide a second 6803 26x17 tool onto the threaded rod.

Thread the Press Tool handle onto the threaded rod.

Turn the handle clockwise to press the bearing into the driver body until it is hand-tight.

Do not overtighten the bearing.

Remove the tools.

NOTICE

To prevent damage when pressing the bearing into the driver body, make sure that the bearing press tools contact both the inner and outer bearing races or bearing bores and not the driver body.

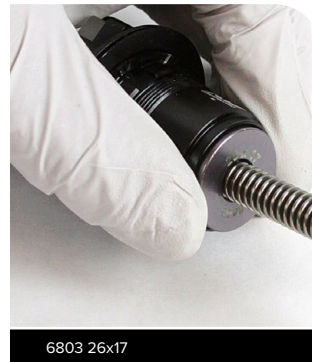

Component Removal

The hub can be serviced while in the wheel. However, if your spokes or rim are damaged, you can remove the hub from the wheel which will make servicing your hub easier. To remove the hub, use a spoke wrench to de-tension the spokes, then use a pair of metal snips to cut the spokes, remove the hub from the wheel, and remove the spoke ends from the hub (not pictured).

For additional information about Zipp wheels and hubs, user manuals are available at www.Zipp.com.

Parts, Tools, and Supplies

Parts

- WHEEL BEARING KIT FRONT/REAR FOR ZIPP ZR1/ZM2 HUBS, 61903
- WHEEL AXLE END CAP SET FRONT - 15X110 BOOST - ZM2 HUBS
- WHEEL AXLE END CAP SET FRONT - 15X110 BOOST - TORQUE CAP ROCKSHOX FORKS - ZM2 HUBS

Safety and Protection Supplies

- Apron
- Clean, lint-free shop towels
- Nitrile gloves
- Safety glasses

Lubricants and Fluids

- Isopropyl alcohol
- Cognition / Klüber Staburags NBU30 grease
- SRAM Butter grease

Bicycle Tools

- Axle and Spindle Vise Inserts - Park Tool AV-4 or AV-5
- Blind Hole Bearing Puller Set
 - 17 mm slotted attachment
- Wheels Manufacturing Press-1 Sealed Bearing Press Kit or similar
 - 6903 30x17 bearing press adapters (x2)
 - T-handle threaded bearing press

Common Tools

- Bench vise
- Flat blade screwdriver
- Grease brush
- Rubber or plastic mallet

SAFETY INSTRUCTIONS

Always wear nitrile gloves when working with bicycle grease.

Exploded View - Front Hub

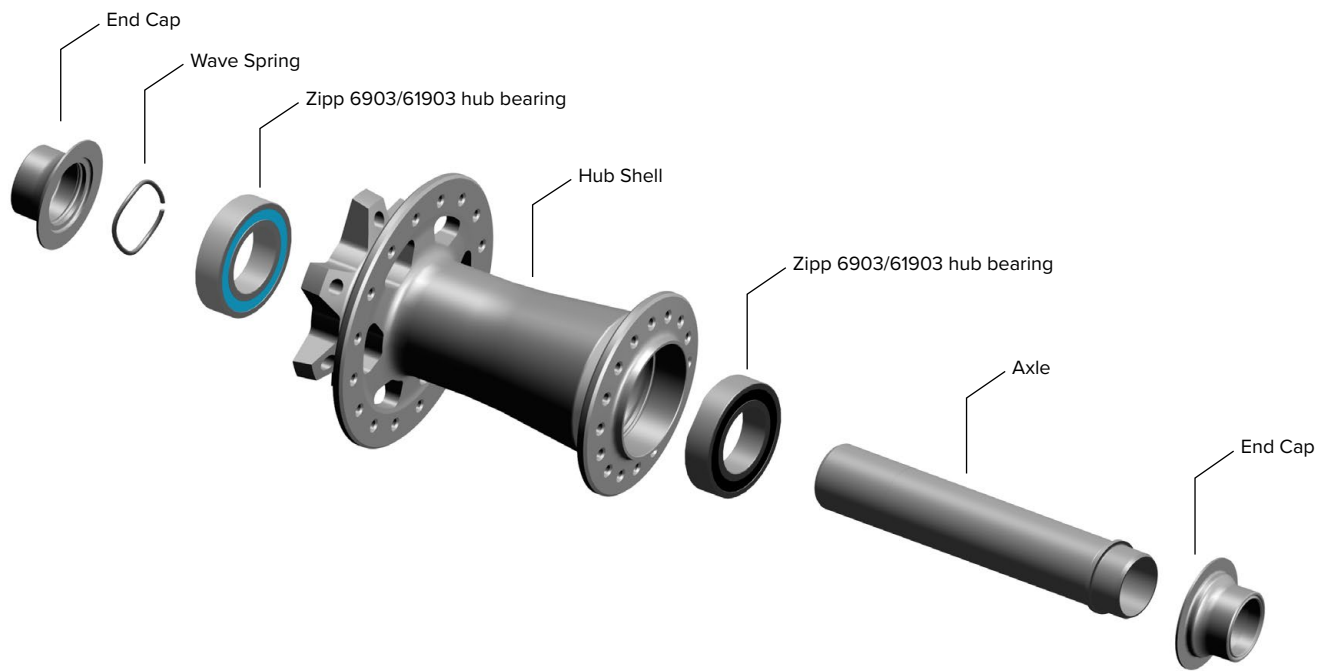

Front Hub End Caps

Hub	Variants			DRIVE SIDE			NON DRIVE SIDE			
				Current Identification Text On End Cap	Previous Identification Text On End Cap	Spare Part Kit Number	Current Identification Text On End Cap	Previous Identification Text On End Cap	Spare Part Kit Number	
ZM2	FRONT	15 x 110	6B	—	165-010	15x(100&110) DS DISC	11.2018.064.001	165-010	15x(100&110) DS DISC	11.2018.064.001
		15 x 110RS		—	189-000	15x(100/110)RS DS 6B	11.2018.064.002	189-000	15x(100/110)RS DS 6B	11.2018.064.002

Front Hub Bearing Removal

- 1 Insert the Park Tool AV-4 or AV-5 Axle and Spindle Vise Insert tool into a vise. Clamp the non-drive side end cap into the vise insert tool and pull up on the wheel/hub to remove the end cap.



- 2 Gently tap the exposed axle end with a plastic mallet to dislodge the axle from the hub bearings.

Use your thumb to push the axle through the hub shell and remove the wave spring from the non drive side hub shell.

NOTICE

Do not discard or misplace the wave spring. It is crucial to hub performance and the hub will not function properly without the spring.

Remove the front axle from the drive side of the hub.



- 3 Use your fingers to remove the end cap from the drive side of the axle.



- 4 Spray isopropyl alcohol onto the axle and clean it with a shop towel.

NOTICE

To prevent damage to the hub surfaces, do not use acetone or similar products to clean parts.



Isopropyl Alcohol

- 5 Insert the 17 mm Bearing Puller slotted attachment through the drive side bearing. Align the slotted attachment with the bottom of the bearing, and expand it inside the bearing.

Do not over tighten the slotted attachment. For more detailed assembly and usage, see the bearing puller manufacturer's instructions.

Grip the slide hammer and forcefully pull away from the slotted attachment to remove the bearing from the hub shell.



17 mm Slotted Attachment



- 6 Insert the 17 mm Bearing Puller slotted attachment through the non-drive side bearing. Align the slotted attachment with the bottom of the bearing, and expand it inside the bearing.

Do not over tighten the slotted attachment. For more detailed assembly and usage, see the bearing puller manufacturer's instructions.

Grip the slide hammer and forcefully pull away from the slotted attachment to remove the bearing from the hub shell.



17 mm Slotted Attachment

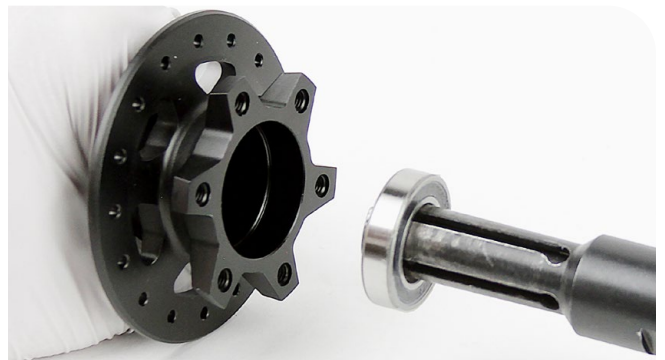

7 Clean the hub shell with isopropyl alcohol and a shop towel.



Isopropyl Alcohol



Shop Towel

Front Hub Bearing Installation

- 1 Install a new Zipp 6903/61903 hub bearing into the drive side of the hub with the **black** seal facing outward.

Note: Ceramic bearings have **blue** seals on both sides of the bearing; installation orientation is not important.



- 2 Slide a 6903 30x17 tool onto the Press Tool threaded rod. Insert the threaded rod through the bearing on the drive side of the hub shell. Slide a second 6903 30x17 tool onto the threaded rod.

Thread the Press Tool handle onto the threaded rod.

Turn the handle clockwise to press the bearing into the hub until it is hand-tight.

Do not overtighten the bearing.

Remove the tools.

NOTICE

To prevent damage when pressing the bearing into the hub, make sure that the bearing press tools contact both the inner and outer bearing races or bearing bores and not the hub shell.

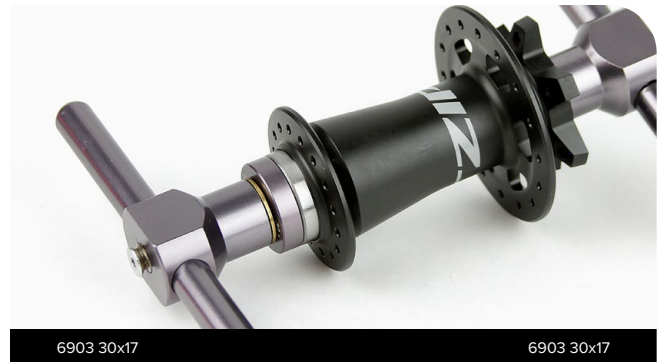

- 3 Install a new Zipp 6903/61903 hub bearing into the non-drive side of the hub with the **black** seal facing outward.

Note: Ceramic bearings have **blue** seals on both sides of the bearing; installation orientation is not important.



- 4** Slide a 6903 30x17 tool onto the Press Tool threaded rod.
- Insert the threaded rod through the bearing on the non-drive side of the hub shell. Slide a second 6903 30x17 tool onto the threaded rod.
- Thread the Press Tool handle onto the threaded rod.
- Turn the handle clockwise to press the bearing into the hub until it is hand-tight.
- Do not overtighten the bearing.
- Remove the tools.



- 5** Apply grease to the non-drive side axle bearing race.



- 6** Insert the non-drive side end of the axle into the drive side of the hub, through the drive side bearing, through the hub, and through the non-drive side bearing. Press the axle into the hub bearing with your thumb until the axle bearing step fits flush into the bearing.



- 7** Install the wave spring onto the non-drive side of the axle. You may need a tool to press the wave spring against the bearing face.

NOTICE

Do not scratch the axle when using a tool to install the wave spring.

The wave spring is crucial to hub performance and must be installed onto the axle.



- 8** Apply grease to the following locations on the drive side and non-drive side axle end:

- Axle front surface (a)
- Axle radial surface (b)
- Bearing front face across bearing seal, inner- and outer ring (c)

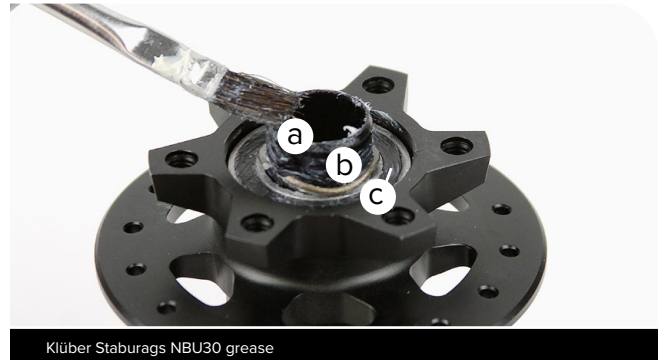

- 9** Press the end caps onto the axle.



- 10** Clean the hub with isopropyl alcohol and a shop towel.



These are registered trademarks of SRAM, LLC:

1:1®, Accuwatt®, Avid®, ATAC®, AXS®, Bar®, Bioposition®, Blackbox®, BoXXer®, DoubleTap®, eTap®, Firecrest®, Firex®, Grip Shift®, GXP®, Holzfeller®, Hussefelt®, Icllic®, i-Motion®, Judy®, Know Your Powers®, NSW®, Omnium®, Osmos®, Pike®, PowerCal®, PowerLock®, PowerTap®, Qollector®, Quarq®, RacerMate®, Reba®, Rock Shox®, Ruktion®, Service Course®, ShockWiz®, SID®, Single Digit®, Speed Dial®, Speed Weaponry®, Spinscan®, SRAM®, SRAM APEX®, SRAM EAGLE®, SRAM FORCE®, SRAM RED®, SRAM RIVAL®, Stylo®, TIME®, Truativ®, TyreWiz®, UDH®, Varicrank®, Velotron®, X0®, X01®, X-SYNC®, XX1®, Zipp®

These are registered logos of SRAM, LLC:



These are trademarks of SRAM, LLC:

10K™, 1X™, 202™, 30™, 30 Course™, 35™, 302™, 303™, 353™, 404™, 454™, 808™, 858™, 3ZERO MOTO™, ABLC™, AeroGlide™, AeroBalance™, AeroLink™, Airea™, Air Guides™, AKA™, AL-7050-TV™, Atmos™, Automatic Drive™, AxCad™, Axial Clutch™, Base™, BB5™, BB7™, BB30™, Bleeding Edge™, Blipbox™, BlipClamp™, BlipGrip™, Blips™, Bluto™, Bottomless Tokens™, Cage Lock™, Carbon Bridge™, Centera™, Charger 2™, Charger™, Charger Race Day™, Cleansweep™, Clickbox Technology™, Clics™, Code™, Cognition™, CoLab™, Connectamajig™, Counter Measure™, CYCLO™, DD3™, DD3 Pulse™, DebonAir™, Deluxe™, Deluxe Re:Aktiv™, Descendant™, DFour™, DFour91™, DH™, Dig Valve™, DirectLink™, Direct Route™, Domain™, DOT 5.1™, Double Decker™, Double Time™, Dual Flow Adjust™, Dual Position Air™, DUB™, DUB-PWR™, DZero™, E300™, E400™, Eagle™, E-Connect4™, ErgoBlade™, ErgoDynamics™, ESP™, EX1™, Exact Actuation™, Exogram™, Flow Link™, FR-5™, Full Pin™, G2™, G40™, Giga Pipe™, Gnar Dog™, Guide™, GS™, GX™, Hard Chrome™, Hexfin™, HollowPin™, Howitzer™, HRD™, Hybrid Drive™, Hyperfoil™, i-3™, Impress™, Jaws™, Jet™, Kage™, Komfy™, LINK™, Lyrik™, MatchMaker™, Maxle™, Maxle 360™, Maxle DH™, Maxle Lite™, Maxle Lite DH™, Maxle Stealth™, Maxle Ultimate™, Micro Gear System™, Mini Block™, Mini Cluster™, Monarch™, Monarch Plus™, Motion Control™, Motion Control DNA™, MRX™, MX™, Noir™, NX™, OCT™, OmniCal™, OneLoc™, Paceline™, Paragon™, PC-1031™, PC-1110™, PC-1170™, PG-1130™, PG-1050™, PG-1170™, Piggyback™, Poploc™, Power Balance™, Power Bulge™, PowerChain™, PowerDomeX™, Powered by SRAM™, PowerGlide™, PowerLink™, Power Pack™, Power Spline™, Predictive Steering™, Pressfit™, Pressfit 30™, Prime™, Qalvin™, R2C™, Rapid Recovery™, Re:Aktiv ThruShaft™, Recon™, Reverb™, Revelation™, Riken™, Roller Bearing Clutch™, Rolling Thunder™, RS-1™, Rush™, RXS™, Sag Gradients™, Sawtooth™, SCT - Smart Coasterbrake Technology, Seeker™, Sektor™, SHIFT™, ShiftGuide™, Shorty™, Showstopper™, SIDLuxe™, Side Swap™, Signal Gear Technology™, SL™, SL-70™, SL-70 Aero™, SL-70 Ergo™, SL-80™, SL-88™, SLC2™, SL SPEED™, SL Sprint™, Smart Connect™, Solo Air™, Solo Spoke™, Speciale™, SpeedBall™, Speed Metal™, SRAM APEX 1™, SRAM Force 1™, SRAM RIVAL 1™, S-series™, Stealth-a-majig™, StealthRing™, Super-9™, Supercork™, Super Deluxe™, Super Deluxe Coil™, SwingLink™, SX™, Tangente™, TaperCore™, Timing Port Closure™, TSE Technology™, Tool-free Reach Adjust™, Top Loading Pads™, Torque Caps™, TRX™, Turnkey™, TwistLoc™, VCLC™, Vivid™, Vivid Air™, Vuka Aero™, Vuka Alumina™, Vuka Bull™, Vuka Clip™, Vuka Fit™, Wide Angle™, WiFLi™, X1™, X3™, X4™, X5™, X7™, X9™, X-Actuation™, XC™, X-Dome™, XD™, XDR™, XG-1150™, XG-1175™, XG-1180™, XG-1190™, X-Glide™, X-GlideR™, X-Horizon™, XLoc Sprint™, XPLR™, XPRESSO™, XPRO™, X-Range™, XX™, Yari™, ZEB™, Zero Loss™, ZM2™, ZR1™



Specifications and colors subject to change without prior notice.

© 2021 SRAM, LLC

The logo for ZIIPP, featuring the word "ZIIPP" in a bold, italicized, white sans-serif font on a black rectangular background.

ASIAN HEADQUARTERS

SRAM Taiwan
No. 1598-8 Chung Shan Road
Shen Kang Hsiang, Taichung City
Taiwan R.O.C.

WORLD HEADQUARTERS

SRAM LLC
1000 W. Fulton Market, 4th Floor
Chicago, Illinois 60607
U.S.A.

EUROPEAN HEADQUARTERS

SRAM Europe
Paasbosweg 14-16
3862ZS Nijkerk
The Netherlands